

NetVista™



N2800e Thin Client Express Reference September 2000

To view or print the latest update, go to <http://www.ibm.com/nc/pubs>

NetVista™

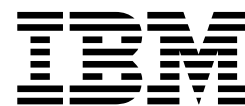

N2800e Thin Client Express Reference September 2000

To view or print the latest update, go to <http://www.ibm.com/nc/pubs>

Note

Before using this information and the product that it supports, be sure to read "Safety notices" on page v and "Notices" on page 61.

First Edition (September 2000)

© Copyright International Business Machines Corporation 2000. All rights reserved.

US Government Users Restricted Rights - Use, duplication or disclosure restricted by GSA ADP Schedule Contract with IBM Corp.

Contents

Safety notices	v	Maintaining and reconfiguring PPP dialer parameters	23
Danger notices	v	Using the PPP dialer to access flash images.	24
Caution notices	vi	Troubleshooting PPP dialer problems.	24
Handling static-sensitive devices	vi		
About this book.	vii	Altering the flash image of a workstation.	25
Who should read this book	vii	Performing a software update on a workstation	25
Information available on the World Wide Web	vii	Using the Configuration Tool to perform a software update on a workstation	25
Related information	vii	Using the Thin Client Manager Operations Utility to perform a software update on a workstation	26
How to send your comments	vii	Recovering the flash image of a workstation	26
		Using one workstation to recover the flash image of another workstation	27
		Using the Setup Utility to recover the flash image of a workstation	29
		Using the Thin Client Manager Operations Utility to recover the flash image of a workstation.	30
Understanding your NetVista Thin Client Express.	1		
		Resolving hardware problems.	31
Learning about the hardware	3	Verifying hardware problems	31
Standard hardware	3	Visible hardware failure	32
Hardware connectors	3	Audio beep sequences.	34
Communication hardware	4	LED indications	35
Monitor specifications	4	Error codes and text messages	36
Power consumption	4		
Upgrading hardware features.	4	Appendix A. Replacing hardware parts 41	
		Replacing the N2800e Thin Client Express CompactFlash card	41
		Replacing parts other than the N2800e CompactFlash card	42
		Returning hardware parts	44
Setting up the hardware.	7	Appendix B. Hardware maintenance procedures	45
Startup sequence	9	Appendix C. Setting the thin client voltage for your location	51
Configuring the N2800e Thin Client Express	11	Appendix D. Recovering the boot block image	53
Using the Setup Utility to configure the workstation	11		
Using the Configuration Tool to configure the workstation	12	Appendix E. Choosing a flash file	55
Installing the Thin Client Service Utility and the Operations Utilities.	15	Appendix F. Monitor specifications	57
Installing the utilities from the NetVista Thin Client Utilities CD	16		
Downloading the utilities from the NetVista Thin Client web site	16	Appendix G. Connector pin information 59	
Managing your Thin Client Express remotely	19	Notices	61
		Environmental Design.	62
		Product Recycling and Disposal	62
PPP dialer for Thin Client Express workstations	21		
Prerequisites for using PPP dial access	21		
Configuring a workstation for PPP dialer	21		
Preparing the workstation for PPP dialer configuration	21		
Configuring initial modem settings for PPP dialer access	22		
Starting the PPP dialer.	23		
Learning about the NC dialer window	23		

Trademarks 63
Electronic Emission Notices 63
 Federal Communications Commission (FCC)
 Statement 63

Glossary of abbreviations 65
Index 67

Safety notices

Safety notices contain information that is related to using the IBM® NetVista thin client in a safe manner. These notices can be in the form of a danger, caution, or attention notice.

Danger notices

The following danger notices call attention to situations that are potentially lethal or extremely hazardous. These notices pertain throughout this book.

DANGER

To prevent a possible electrical shock during an electrical storm, do not connect or disconnect cables or station protectors for communications lines, display stations, printers, or telephones. (RSFTD003)

DANGER

To prevent a possible electrical shock from touching two surfaces with different electrical grounds, use one hand, when possible, to connect or disconnect signal cables. (RSFTD004)

DANGER

An electrical outlet that is not correctly wired could place hazardous voltage on metal parts of the system or the products that attach to the system. It is the customer's responsibility to ensure that the outlet is correctly wired and grounded to prevent an electrical shock. (RSFTD201)

DANGER

To prevent a possible electrical shock when installing the system, ensure that the power cords for all devices are unplugged before installing signal cables. (RSFTD202)

DANGER

To prevent a possible electrical shock when adding the device to a system, disconnect all power cords, if possible, from the existing system before connecting the signal cable to that device. (RSFTD205)

DANGER

To prevent a possible electrical shock, disconnect the power cord from the electrical outlet before opening the unit. (RSFTD215)

DANGER

To reduce the risk of electrical shock use only AC power sources approved by IBM. (RSFTD216)

Caution notices

A caution notice applies to a situation that is potentially hazardous to people because of some existing condition.

CAUTION:

The battery is a lithium battery. To avoid possible explosion, do not burn or charge the battery. Exchange only with the IBM-approved part. Discard the battery as instructed by local regulations. (RSFTC227)

Handling static-sensitive devices

When you handle components, take these precautions to avoid static electricity damage:

- Do *not* open static-protective packages until you are ready to install their contents.
- Limit your movements to avoid static electricity build-up around you.
- Handle components carefully, and never touch exposed circuitry.
- Prevent others from touching components.
- Place components on static-protective packages while performing hardware removal and installation procedures.
- Do not place components on metal surfaces.

About this book

IBM NetVista N2800e Thin Client Express Reference (SA23-2808) provides information for the Type 8364 (Model Cxx) IBM NetVista N2800e Thin Client Express (hereafter referred to as *workstation* or *thin client*).

This publication contains information on hardware setup, software configuration and update, hardware problem resolution, hardware upgrade options, parts replacement, and ordering.

Who should read this book

The following should find the information in this publication helpful:

- The person who administers the workstation
- The hardware service, and the support organizations for the workstation

Information available on the World Wide Web

You can obtain the latest version of this information at the following uniform resource locator (URL):

<http://www.ibm.com/nc/pubs>

This is the same URL that is printed on the cover of this document.

Related information

The following publications ship with your hardware. Refer to these publications for information that relates to your workstation:

- See the *IBM NetVista Quick Setup for N2800e Thin Client Express, Type 8364 (Model Cxx)* (SA23-2807) pamphlet for quick hardware setup information and software configuration information.
- See the *IBM License Agreement For Machine Code* (Z125-5468) before using the workstation.
- See *IBM NetVista Thin Client Safety Information* (SA41-4143) for important safety notices.
- See *IBM NetVista Thin Client Hardware Warranty - Type 8363 and Type 8364* (SA23-2802) for important hardware warranty information.

Refer to *IBM NetVista Thin Client Manager Operations Utility* (SA23-2813) for information about managing your Thin Client Express. This information is available at the following URL:

<http://www.ibm.com/nc/pubs>

How to send your comments

Your feedback is important in helping to provide the most accurate and high-quality information. You can submit comments about this, or other IBM information by mailing the readers' comment form, located at the end of this information.

- If you are mailing comments from a country other than the United States, you can give the form to the local IBM branch office or IBM representative for postage-paid mailing.
- If you prefer to send comments by FAX, use either of the following telephone numbers:
 - United States and Canada: 1-800-937-3430
 - Other countries: 1-507-253-5192
- If you prefer to send comments electronically, use the following network identification:
 - IBMMAIL, to IBMMAIL(USIB56RZ)
 - RCHCLERK@us.ibm.com

Be sure to include the following:

- The title, and order number of the information
- The page number or topic to which your comment applies

Understanding your NetVista Thin Client Express

The IBM NetVista N2800e Thin Client Express offers a fast and simple way to access applications on the following platforms:

- Windows NT[®] Server 4.0
- Windows NT Server 4.0, Terminal Server Edition (TSE)
- Windows NT Workstation 4.0
- Windows[®] 2000 Server
- Windows 2000 Professional
- Windows 2000 Advanced Server

As both a hardware and a software solution, Thin Client Express includes essential Network Station[™] Manager V2R1 functions on a pre-installed CompactFlash card.

Thin Client Express provides the usual thin-client benefits, such as a reduced total cost of ownership and the fast, flexible deployment of applications. Because it does not require a boot server, Thin Client Express also provides a quick start-up time.

Thin Client Express also includes a Setup Utility, and a Configuration Tool that provide the following:

- A streamlined configuration process
- Local boot capabilities from a CompactFlash card
- A Netscape browser
- 3270, 5250, and VTxx emulator sessions
- An Independent Computing Architecture (ICA) client and ICA Remote Application Manager
- Separate utility programs for flash update service and operations management
- A desktop with a Launch Bar or one or more full-screen applications
- Advanced diagnostics

The IBM NetVista Thin Client Express Service Utility and IBM NetVista Thin Client Manager Operations Utility are management utilities that you can use to manage your workstations. These utilities run on Windows 2000 and Windows NT workstations, and are available to you, free of charge. You can download these utilities either from a compact disc (CD) or from the World Wide Web. For information on obtaining the CD (at no cost to you), visit the following uniform resource locator (URL):

<http://www.pc.ibm.com/us/netvista/thinclient/xpress.html>

Click **Express Utilities**, located under the **More Info** heading.

If you are interested in downloading the utilities from the World Wide Web, refer to “Downloading the utilities from the NetVista Thin Client web site” on page 16 for more information.

Learning about the hardware

This section provides detailed hardware information about the N2800e Thin Client Express — Hardware Type 8364 (Model Cxx), hereafter referred to as N2800e Thin Client Express.

Standard hardware

The standard N2800e Thin Client Express hardware includes the following:

- 64 MB of SDRAM DIMM random access memory (RAM) (see “Appendix A. Replacing hardware parts” on page 41).
- 4 MB SGRAM video memory
- Integrated Ethernet communication
- 16-bit internal and external sound
- One 32 MB CompactFlash card with preloaded software
- 2 USB ports for a keyboard and other USB devices
- 2 PCI adapter slots for PCI devices
- Two serial ports for serial devices

Note: The Netscape browser requires 64 MB of RAM. See “Appendix B. Hardware maintenance procedures” on page 45 for information about adding more memory to a workstation. See “Appendix A. Replacing hardware parts” on page 41 for information about ordering replacement memory.

Hardware connectors

Your N2800e Thin Client Express hardware includes standard connectors, standard pin, signal, and signal direction configurations. See “Appendix G. Connector pin information” on page 59 for details.

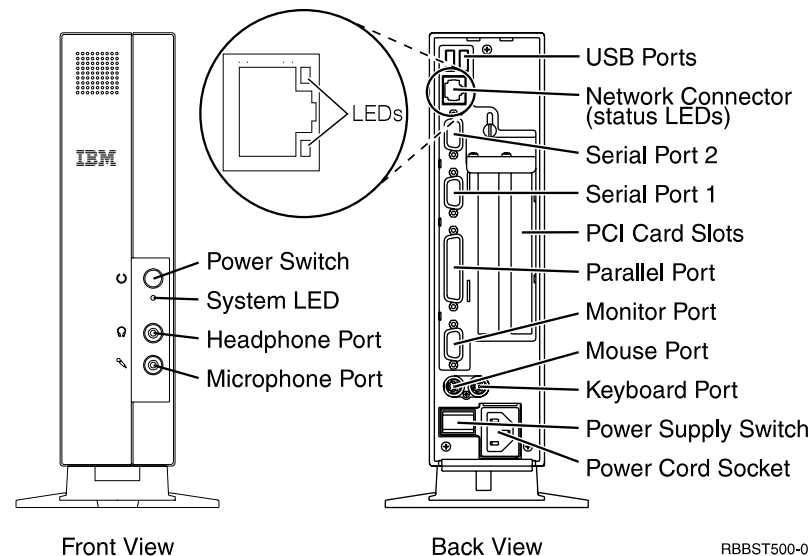

Figure 1. Hardware connectors

Communication hardware

Your N2800e Thin Client Express includes an integrated Ethernet connection.

For a 10 Megabit (Mb) line speed operation, you need a category 3 or higher Unshielded Twisted Pair (UTP) type of cable. For a 100 Mb line speed operation, you need a category 5 UTP type of cable.

Refer to “Appendix G. Connector pin information” on page 59 for communication cable specifications.

Monitor specifications

A basic video graphics adapter (VGA) class monitor that meets the Video Electronics Standards Association (VESA) standards of refresh rate and resolution functions with the N2800e Thin Client Express. The N2800e Thin Client Express can support VESA Display Power Management Signaling (DPMS) and VESA Display Data Channel (DDC2B).

Refer to “Appendix F. Monitor specifications” on page 57 for a list of resolutions and refresh rates that the N2800e Thin Client Express can support. Your monitor may not support all resolutions and refresh rates.

Power consumption

Normal power consumption for the thin client, while running applications, ranges from 24 to 28 Watts. During periods of inactivity, the system switches into the suspend state, and power consumption reduces to approximately 18 Watts. Once the system enters the soft-off state, power consumption reduces to approximately 10 Watts.

Note: Power consumption may fluctuate or vary from these values, depending on the voltage selection (115V or 230V) of the thin client.

Display monitor power reduction occurs when you use the N2800e Thin Client Express with a VESA DPMS Standard monitor.

As an Energy Star Partner, IBM has determined that this product meets the Energy Star Program guidelines for energy efficiency.

Upgrading hardware features

You can perform the following hardware procedures:

- Install PCI adapter cards for PCI devices
- Replace a CompactFlash card
- Connect USB devices

If you plan to use peripheral USB devices with your N2800e Thin Client Express, refer to the documentation for your peripheral USB devices for information.

- Upgrade your memory

The N2800e Thin Client Express has two random access memory (RAM) slots that accepts Synchronous Dynamic Random Access Memory (SDRAM) Dual Inline Memory Modules (DIMMs). The N2800e Thin Client Express includes 64 MB of RAM, and supports memory expansions of up to 256 MB. You can

expand the RAM of the N2800e by installing 32, 64, or 128 MB DIMMs. “Appendix B. Hardware maintenance procedures” on page 45 provides information on how to exchange memory. Refer to “Appendix A. Replacing hardware parts” on page 41 for detailed memory specifications and orderable N2800e Thin Client Express parts.

Note: Use of the Netscape browser requires 64 MB of RAM.

Setting up the hardware

Unpacking your hardware

Unpack your hardware. Contact your reseller, or IBM, if you do not have these standard parts:

- 1 Thin client logic unit
- 2 Base
- 3 Mouse
- 4 Keyboard
- 5 Power cable

Selecting the voltage for your location:

Attention: You may damage the thin client if you do not select the correct voltage.

1. Locate the voltage switch **A** on the bottom of the thin client.
2. Use a pen, or similar object, to slide the switch **A** to the correct setting for your location (see "Voltage selection" in Table 11 on page 42).

Installing options:

- If you have additional memory, or optional feature cards, see "Appendix B. Hardware maintenance procedures" on page 45 before continuing with the following setup procedures.
- If you have a security cable and would like to restrict access to the thin client logic unit, thread your cable through hole **B**.
- For vertical placement of the thin client, see "Installing the support base" on page 8.
- For horizontal placement of the hardware, continue with "Connecting your hardware" on page 8.

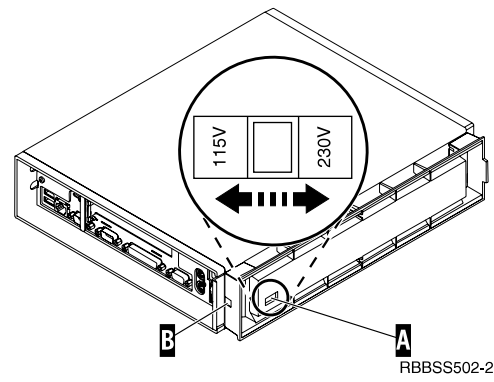
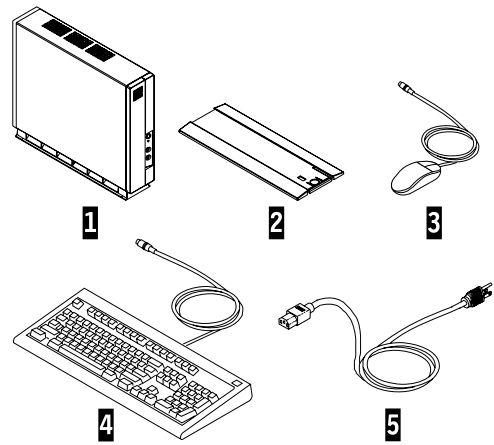

Installing the support base

Slide the base **B** onto the notched bottom of the thin client **A** until it latches securely.

Connecting your hardware

Read “Safety notices” on page v before continuing.

1. Connect the devices listed below to the appropriate ports:
 - 1** USB devices
 - 2** Network cable
 - 3** Serial device 2
 - 4** Serial device 1
 - 5** Parallel devices
 - 6** Monitor
 - 7** Mouse
 - 8** Keyboard
 - 13** Headphones
 - 14** Microphone
2. Tighten all device cable connections.
3. Connect the thin client power cable to the power socket **10**.
4. Plug all power cables into properly grounded working electrical outlets.
5. To power on your thin client, move the power supply switch **9** to the “on” position.

Notes:

- a. The white power switch **11** resets the power to your thin client.
 - b. The system LED **12** should flash from amber to green. See “Resolving hardware problems” on page 31 for deviations.
6. Choose the operating system for your server from the menu that appears on your screen. Refer to the server software information to verify the correct selection for your network.

Note: If your thin client is unable to receive the operating system code from the server, contact your network administrator.

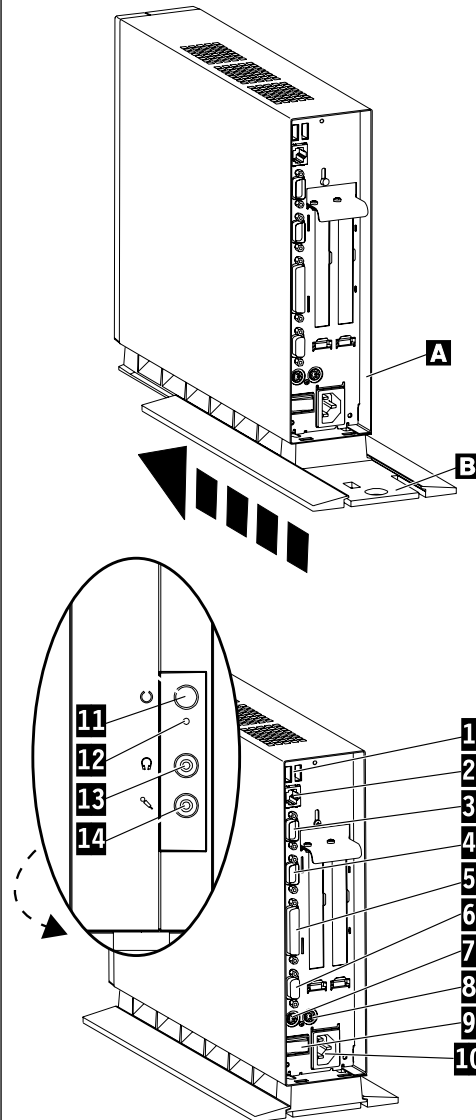

RBBSS503-4

Startup sequence

This is a typical startup sequence of events for the NetVista Thin Client Express. If any of these events do not occur, see “Resolving hardware problems” on page 31.

1. The following devices show light-emitting diode (LED) indications:
 - Logic unit (system LED and network status LED)
 - Keyboard
 - Monitor¹
 - Any USB devices²
2. The following internal hardware components initialize:
 - Memory
 - L1 cache
 - Video memory
 - Keyboard controller
3. The IBM NetVista thin client screen appears on the monitor.
4. One of the following appears:
 - The Thin Client Express Setup Utility. The Setup Utility appears in either of the following situations:
 - You start the NetVista thin client for the first time.
 - You previously reset the NetVista thin client to the factory-default property settings.

The Configuration Tool launches after the Setup Utility in either situation.

Refer to “Configuring the N2800e Thin Client Express” on page 11 for more information about working with the Setup Utility.

- The NetVista Thin Client Express detects the CompactFlash card and loads the operating system into memory.
- The interface that you specified with the Configuration Tool appears. The interface can be either of the following:
 - One or more applications
 - A launch bar with one or more applications

Refer to the following sections for more information about configuring your NetVista Thin Client Express:

- “Configuring the N2800e Thin Client Express” on page 11
- “Installing the Thin Client Service Utility and the Operations Utilities” on page 15
- “Managing your Thin Client Express remotely” on page 19

1. Refer to the documentation for your monitor if there is no LED indication.

2. Refer to the documentation for your USB devices if there are no LED indications.

Configuring the N2800e Thin Client Express

Before you can use the N2800e Thin Client Express (also referred to as *workstation*) to access server applications, you need to configure your workstation. You can use the NSBoot Setup Utility (also referred to as *Setup Utility*) and the Thin Client Express Configuration Tool (or *Configuration Tool*) to configure workstations.

Note: You do not need access to an external server to set up and configure the workstation.

This section provides information on the following:

- “Using the Setup Utility to configure the workstation”
- “Using the Configuration Tool to configure the workstation” on page 12

Using the Setup Utility to configure the workstation

The Setup Utility allows you to perform the following tasks:

- Specify your keyboard language settings
- Set the resolution and frequency of your display
- Configure your Internet Protocol (IP) settings
- Perform advanced configurations, such as changing your boot file server settings

The first time you start the workstation, you must use the initial Setup Utility to configure the workstation. The following menu is an example of a Setup Utility menu:

```
MENU2x A                IBM NetVista Thin Client
                        CompactFlash boot - Configure IP settings B

Dial access ..... Disabled
DHCP ..... Disabled

Thin Client IP address ..... [0.0.0.0]
Subnet mask ..... [255.255.255.0]

Gateway IP address ..... [0.0.0.0]
Domain name server IP address ..... [0.0.0.0]
      └───────────┬───────────┘
      C           D

                        Press Enter to continue. E
                        Leave at 0.0.0.0 if a Domain Name Server is not used F
                        Thin Client IP address is required G

Enter=Continue  F5=Advanced configuration  F7=Back H
```

RZAPN500-3

Figure 2. Example menu

The menu number **A** makes it easy to navigate through the Setup Utility. Menu numbers that begin with **2** are unique to the initial Setup Utility. The menu title **B** tells you which menu you are using.

Use the arrow keys to select an option from the list of available options **C**. After you select an option, specify a value in the corresponding value field **D**. Certain fields allow you to select a value by using the **Page Up** and **Page Down** keys.

Instructions and other messages (**E** and **F**) provide additional information. Error messages **G** inform you when you need to complete a field or correct a value before continuing.

Use the active function keys **H** to navigate through the Setup Utility.

To access the Setup Utility during a subsequent boot, press **Esc** immediately after the following message disappears:

Hardware testing in progress . . .

If you worked only with the **Simple Configuration** menu during the initial boot, then the **Simple Configuration** menu appears. However, if you worked with the **Advanced Configuration** menu during the initial boot, then the **Advanced Configuration** menu appears.

You can also configure your workstation for Dial Access. This option is available if your client will use a modem for network connection instead of the Ethernet or Token-Ring connection. See “PPP dialer for Thin Client Express workstations” on page 21.

For information on using the Setup Utility to update CompactFlash cards, see “Using the Setup Utility to recover the flash image of a workstation” on page 29.

Using the Configuration Tool to configure the workstation

The Configuration Tool allows you to configure the following applications on your workstation:

- Independent Computing Architecture (ICA) Client
- ICA Remote Application Manager
- Netscape 4.5 browser (without Netscape JVM support)
- 3270 emulator to S/390[®] hosts
- 5250 emulator to Application System/400 (AS/400)[®] hosts
- VT emulator
- Advanced diagnostics

The Configuration Tool also allows you to configure the single user preferences that are independent of the applications, such as mouse orientation. It also provides a means to update the software on the CompactFlash card.

The first time you power on the workstation, the Configuration Tool displays automatically after you complete the Setup Utility configurations. You must complete the Configuration Tool configurations before you can access applications from network servers. However, you do not need to complete the advanced settings to create a basic, working configuration. After you have completed the Configuration Tool, click **Save and Restart** to save your settings and restart the workstation with your new configuration.

The Configuration Tool provides three Workstation Mode user interfaces:

1. A single application that starts automatically when you power on the workstation. This application fills the entire display screen.
2. One or more applications that start automatically when you power on the workstation.

Note: The N2800e's free memory determines how many applications you can run at one time. With 32 MB of RAM, you can specify up to either of the following applications:

- Four simultaneous 5250 or 3270 emulators
 - An ICA client and two simultaneous 5250 or 3270 emulators
3. A launch bar with one or more applications. The Configuration Tool can start these applications automatically, if desired.

Network administrators can use one of two possible methods to restrict access to the Configuration Tool:

1. Use the Configuration Tool itself to create an administrator password.
2. Use the Thin Client Manager Operations Utility. For more information on using the Thin Client Manager Operations Utility, see "Managing your Thin Client Express remotely" on page 19.

You can access additional, customized help at any time by clicking **Help** in the lower, right-hand corner of the display. The help viewer also has search capability.

To access the Configuration Tool anytime after the initial configuration, press and hold the following keys on the left side of the keyboard: **Shift + Ctrl + Alt**. Hold the keys down for several seconds until the Configuration Tool starts.

You can also place the Configuration Tool on the launch bar for simple, future access.

For information on using the Configuration Tool to update CompactFlash cards, see "Using the Configuration Tool to perform a software update on a workstation" on page 25.

Installing the Thin Client Service Utility and the Operations Utilities

The Thin Client Express Service and Thin Client Manager Operations Utilities are management utilities that run on the following workstations or server platforms:

- Windows NT Server 4.0
- Windows NT Server 4.0, Terminal Server Edition (TSE)
- Windows NT Workstation 4.0
- Windows 2000 Server
- Windows 2000 Professional
- Windows 2000 Advanced Server

Although these utilities are optional, IBM recommends that you install the Service Utility on if you want to rewrite the flash image of a workstation. The Service Utility consists of the following:

- NetVista Thin Client Express image files
- Network support services that provide Network File System (NFS) support for the client to access the image files

The Service Utility services start automatically after the installation is complete. The services also start automatically after the server reboots. If you experience problems while attempting to update or recover the flash of a workstation, verify the status of the Service Utility network support services. For information regarding how to verify the status of network support services, see the NetVista Thin Client Service and Operations Utilities Readme file. This file is available on the NetVista Thin Client Utilities CD, as well as the NetVista Thin Client website.

For information on using the Operations Utility, refer to *IBM NetVista Thin Client Manager Operations Utility (SA23-2812)*. This information is available at the following uniform resource locator (URL):

<http://www.ibm.com/nc/pubs>

Table 1 shows the tools, and utilities that IBM recommends for the different methods of rewriting the flash image.

Table 1. Required tools and utilities to perform flash updates and recoveries

Type of update or recovery	NSBoot Setup Utility	Configuration Tool	Service Utility	Operations Utility
Configuration Tool update		X	X	
Operations Utility update			X	X
Operations Utility recovery			X	X
NS Boot Setup Utility recovery	X		X	
Peer flash recovery	X			

Only the Operations Utility methods of updating in Table 1 on page 15 allow you to update multiple workstations at a time. The other methods of flash recovery in Table 1 on page 15 allow you to perform flash recovery to one workstation at a time. For more information on recovering or updating CompactFlash cards with the TCM Operations Utility, refer to *IBM NetVista Thin Client Manager Operations Utility* (SA23-2812). This information is available at the following URL:

<http://www.ibm.com/nc/pubs>

There are two ways to install the Service and Operations Utilities:

1. Installing the utilities from the NetVista Thin Client Utilities CD
2. Downloading the utilities from the NetVista Thin Client website

Installing the utilities from the NetVista Thin Client Utilities CD

To install the Service and Operations Utilities from the NetVista Thin Client Utilities CD, insert the CD into your server's CD-ROM drive. The IBM NetVista Thin Client Utilities menu starts automatically.

Note: If the Thin Client Utilities menu does not start automatically, you can run the `install.bat` file from the root directory of the CD.

To install the Operations Utility, click "Install NetVista Thin Client Manager Operations Utility."

To install the Service Utility, click "Install NetVista Thin Client Express Service Utility."

Downloading the utilities from the NetVista Thin Client web site

To download the Service and Operations Utilities from the IBM Thin Client web site, you need to set up an update server. This update server must meet the following requirements:

- Reliable access to the Internet
- Runs File Transfer Protocol (FTP) or Hypertext Transfer Protocol (HTTP)
- Accessible by workstations through a high-speed TCP/IP (Transmission Control Protocol/Internet Protocol) connection (for example, a LAN)
- Sufficient space for the download files

After you have set up an update server, follow these steps to download the Service and Operations Utilities from the IBM Thin Client web site:

Note: The Thin Client Express Service Utility, Thin Client Manager Operations Utility, and Readme files for each utility are available from this Internet site.

1. From the server that you want to install the utilities on, open an Internet browser and go to the following URL:

<http://www.ibm.com/pc/support>

2. Click **NetVista**.
3. Click **NetVista *thin client***.
4. From the left column of links, click **Hot news**.
5. Click **NetVista Thin Client Express - Service and Operations Utilities**.

6. Click **download NetVista Thin Client Express Service and Operations Utilities**.
7. From the **Downloads** box, click the item that you want to download.

Managing your Thin Client Express remotely

You can use the IBM NetVista Thin Client Manager Operations Utility to remotely manage your N2800e Thin Client Express. You can use the Thin Client Manager Operations Utility to manage both individual workstations, and workstation groups. Before you can use the Operations Utility to perform a task on a workstation, you need to perform the following tasks:

- Install the Operations Utility on your computer. For information on installing the Operations Utility, see “Installing the Thin Client Service Utility and the Operations Utilities” on page 15.
- Power on the workstation on which you want to perform a task.

See *IBM NetVista Thin Client Manager Operations Utility (SA23-2813)* for more information on managing thin clients with the Thin Client Manager Operations Utility. This information is available on the World Wide Web at the following uniform resource locator (URL):

<http://www.ibm.com/nc/pubs>

PPP dialer for Thin Client Express workstations

You can configure your Thin Client Express (hereafter referred to as *workstation*) for Point-to-Point Protocol (PPP) dial access. You can utilize this option if your workstation uses a modem to connect to a network. There are several prerequisites that you must meet before you can use PPP dialer.

Prerequisites for using PPP dial access

Before you can use PPP dial access with your workstation, you must have the following:

- A workstation, with a Service Update 1 BOM flash file installed on its CompactFlash card (see “Altering the flash image of a workstation” on page 25 for flash update information).
- USB modem or serial analog modem.

Note: If you are going to use a serial modem with a N2800e workstation, you need an USB-to-serial adapter.

- Analog telephone line.
- Internet Service Provider (ISP) that supports PPP connections, and Password Authentication Protocol (PAP) authentication.

Note: By default, the workstation does not recognize Domain Name System (DNS) information from ISPs. To enable DNS, perform the procedure, “Configuring initial modem settings for PPP dialer access” on page 22.

For a list of tested modems, visit the following uniform resource locator (URL):
<http://www.ibm.com/pc/support>

Click **NetVista**—>**NetVista thin client**—>**Advanced Search**, and then search for modems, under IBM NetVista Thin Client.

Configuring a workstation for PPP dialer

You need to perform the following procedures to configure a workstation for PPP dialer access:

1. “Preparing the workstation for PPP dialer configuration” on page 21
2. “Configuring initial modem settings for PPP dialer access” on page 22
3. “Starting the PPP dialer” on page 23

Preparing the workstation for PPP dialer configuration

Follow these steps to configure your workstation for PPP dialer access.

1. Power on the workstation.
2. If the workstation does not automatically display the **Setup Utility Simple configuration** menu, press **Esc** to enter the Setup Utility. If the workstation displays the **Advanced configuration** menu, select **Simple configuration**, and press **Enter**.
3. From the **Setup Utility Simple configuration** menu:
 - a. Choose a language setting.

- b. Choose a display resolution setting and a display frequency setting.
- c. Configure the workstation Internet Protocol (IP) settings:
 - 1) From the **CompactFlash Boot - Configure IP settings** menu, disable Dynamic Host Configuration Protocol (DHCP).
 - 2) Verify that all IP values are 0.0.0.0.
 - 3) From the **CompactFlash Boot - Configure IP settings** menu, enable **Dial Access**.
 - 4) Press **Enter**. The workstation restarts, and the Configuration Tool appears on the display. If the Configuration Tool does not display, Press and hold the following keys on the left side of the keyboard: **Shift + Ctrl + Alt**. Hold the keys down for several seconds until the Configuration Tool starts.

Note: If you are unable to enter the Configuration Tool, the workstation may not have access to the Configuration Tool. Refer to *IBM NetVista Thin Client Manager Operations Utility (SA23-2813)* for more information about granting and denying access to the Configuration Tool. This information is available at the following URL:

<http://www.ibm.com/nc/pubs>

4. From the Configuration Tool, select a language.

You have completed the initial configurations of your workstation for PPP dialer access. Continue with "Configuring initial modem settings for PPP dialer access".

Configuring initial modem settings for PPP dialer access

Once you have prepared a workstation for PPP dialer access, you must configure the initial modem settings of the workstation. Perform the following steps from the **Communication Options** menu of the Configuration Tool to complete this task:

1. Select a type of modem. N2800e workstations use an USB modem, or a serial modem.
2. Select DTE Baud rate. If you are using a 56K modem, you should select 57600 or higher.
3. Select a dialing method. You can choose **Tone** or **Pulse**.
4. This step is optional, depending on the modem that you are using:
 - a. Type the modem initialization string in the appropriate field. This can contain additional commands for the modem.
 - b. Type one command string and one response string into the appropriate fields. Refer to the documentation for the modem that you are using for specific commands. An example of a command string and a response string is atz&fL1 OK.
5. This step is optional, depending on the applications that you want to use:
 - a. If you need DNS support, from the **DNS active** pulldown list, select **Yes**.
 - b. Type up to two DNS server IP addresses in the **IP address 1** and **IP address 2** fields.
 - c. Type an optional domain name in the **Domain** field.
6. Type the telephone number of the ISP in the **Phone number** field. You can include commas in the telephone number for time delay, but you cannot include blank spaces. Commas indicate to the PPP dialer that it needs to wait for a dial tone before continuing to dial the telephone number of the ISP.

7. Type a userid and password in the appropriate fields. If you do not type a userid and password, the dialer prompts you for a userid and password each time that you connect to the network.

Once you have completed the initial modem setting configurations for PPP dialer access, you can start the PPP dialer. It is necessary for you to successfully start the PPP dialer at this time to complete the configuration of your workstation for PPP dialer access.

Starting the PPP dialer

You can start the PPP dialer once you have completed the initial modem setting configurations on the workstation. Starting the PPP dialer after you have completed the initial modem setting allows the workstation to test the modem settings that you have specified. Perform the following steps to start the PPP dialer:

1. In the last step of the procedure, “Configuring initial modem settings for PPP dialer access” on page 22, the workstation that you are configuring for PPP dialer access is displaying the **Communication Options** menu. From the **Communication Options** menu, click **OK** to start the dialer.
2. From the **NC Dialer** window, click **Connect**. The workstation may prompt you for a userid and password. After you click **Connect**, the **State** changes from **Offline**, to **Connecting**. Wait for the state to display **Online**. You can check the status log in the window for connection errors.

After the workstation has completed a successful dial connection, the **Configure a Workstation Mode** menu appears. You are now ready to configure the workstation desktop. See “Using the Configuration Tool to configure the workstation” on page 12 for more information about configuring the workstation desktop.

Learning about the NC dialer window

The **NC dialer** window displays information about the PPP connection of the workstation. The dialer window includes a log, which displays status information of the current dialer session. During a successful PPP dialer connection, the dialer window displays the following information:

- **Modem Speed** — displays the DTE Baud speed.
- **Local IP** — displays the local workstation’s IP address.
- **Remote IP**— displays the workstation’s gateway address.
- **Bytes in** — displays number of bytes received by the workstation.
- **Bytes out** — displays number of bytes transmitted by the workstation.
- **Time online** — displays the time online for the current connection.
- **Connect** — if enabled, allows the user to connect manually.
- **Disconnect** — if enabled, allows the user to disconnect manually.

Maintaining and reconfiguring PPP dialer parameters

You can change PPP dialer configuration parameters of a workstation from the Configuration Tool. Perform these steps to reconfigure the PPP dialer parameters for a workstation:

1. From the workstation that you want to update, enter the Configuration Tool:
 - a. Press and hold the following keys on the left side of the keyboard: **Shift + Ctrl + Alt**.

- b. Hold the keys down for several seconds until the Configuration Tool starts.

Note: If you are unable to enter the Configuration Tool, the workstation may not have access to the Configuration Tool. Refer to *IBM NetVista Thin Client Manager Operations Utility* (SA23-2813) for more information about granting and denying access to the Configuration Tool. This information is available at the following URL:

<http://www.ibm.com/nc/pubs>

2. Click **Workstation Configuration**.
3. Select **Hardware—>Communications**. The **Dial Access Configuration** window appears.
4. Change the PPP dialer parameters according to your needs.

You do not need to restart the workstation for the changes to take effect. The next time you start a PPP dialer session, the PPP dialer will use the parameters that you have configured.

Using the PPP dialer to access flash images

You can use the workstation Configuration Tool to update the flash image of a workstation. If you have configured the workstation to use the PPP dialer, the workstation uses the dialer to access the update flash image. See “Using the Configuration Tool to perform a software update on a workstation” on page 25 for more information about using the Configuration Tool to perform software updates. Perform the procedure, “Configuring a workstation for PPP dialer” on page 21, to configure a workstation to use the PPP dialer.

Troubleshooting PPP dialer problems

The NC dialer window displays PPP connection information. The workstation saves this information in the following file: `/tmp/ncdialer/log`.

Note: The `/tmp/ncdialer/log` does not persist through workstation reboot. The workstation stores additional PPP connection information in the system log. You can access this information by performing the following steps:

1. Using the Configuration Tool, configure the workstation desktop to include an **Advanced Diagnostics** window (see “Using the Configuration Tool to configure the workstation” on page 12).
2. From the workstation desktop, open an Advanced Diagnostics window and type the command, `dmesg`. You can now see PPP connection information and messages for the current dialer session.

Altering the flash image of a workstation

There are two methods that you can use to alter the flash image of a workstation:

- “Performing a software update on a workstation” on page 25.
- “Recovering the flash image of a workstation” on page 26.

Notes:

1. When you perform a software *update* to the flash image of a workstation, you are only updating the software files. The workstation saves any configuration settings that you have made, during the software flash update process.
2. When you *recover* the flash image of a workstation, the recovery server reformats the CompactFlash card of the workstation, copying the recovery flash image to the workstation. Any configurations that you have made to the workstation are removed.

Performing a software update on a workstation

You should perform software updates on workstations only when a newer version of the software flash image exists. Files which contain configuration information are not rewritten by the workstation when you perform a software update on a workstation. Configuration files can include Internet Protocol (IP) configuration settings, emulator settings, keyboard remapping files, and Independent Computing Architecture (ICA) Client sessions that you have added.

You can perform a software update on a workstation, using the following two methods:

- “Using the Thin Client Manager Operations Utility to perform a software update on a workstation” on page 26
- “Using the Configuration Tool to perform a software update on a workstation”

Using the Configuration Tool to perform a software update on a workstation

You can use the Configuration Tool to perform a software update on a workstation. Using the Configuration Tool requires you to be at the workstation that you are updating. If you have installed the IBM NetVista Thin Client Express Service Utility (hereafter referred to as *Service Utility*), you can use it as a flash update source. To use the Configuration Tool to perform a software update on a workstation, follow these steps:

1. From the workstation that you want to update, enter the Configuration Tool:
 - a. Press and hold the following keys on the left side of the keyboard: **Shift + Ctrl + Alt**.
 - b. Hold the keys down for several seconds until the Configuration Tool starts.

Note: If you are unable to enter the Configuration Tool, the workstation may not have access to the Configuration Tool. Refer to *IBM NetVista Thin Client Manager Operations Utility (SA23-2813)* for more information about granting and denying workstations access to the Configuration Tool. This information is available at the following uniform resource locator (URL):

<http://www.ibm.com/nc/pubs>

2. If you have installed the Service Utility on a network server, ensure that the Service Utility services are running. If you have not installed the Service Utility on a network server, you can use another workstation as your flash update source. Continue with the next step.
3. From the Configuration Tool, click **Remote Management / Software Update**.
4. Click **Configure Software Update Server Access**.
5. Specify the IP address of the Service Utility server. To use another workstation as your flash update source, enter the IP address of the workstation that you want to pull the software update from.
6. Verify that both the software update server, and the file system types are correct.
7. Set **Software update file list name** to the appropriate flash file, or BOM file. For information on selecting the correct flash file, see “Appendix E. Choosing a flash file” on page 55.
8. Click **OK**.
9. Click **Request Immediate Software Update**.
10. On the confirmation window, click **OK**.
Attention: After you click **OK**, the server might take as long as 10 minutes to update the CompactFlash card. Do **not** power off the workstation while it reboots.

If you are interested in learning more about the Configuration Tool, see “Using the Configuration Tool to configure the workstation” on page 12.

Using the Thin Client Manager Operations Utility to perform a software update on a workstation

You can use the Thin Client Manager Operations Utility to perform a software update on a workstation. To find out how to perform this, and other workstation management tasks, refer to *IBM NetVista Thin Client Manager Operations Utility (SA23-2813)* for information about managing your Thin Client Express. This information is available at the following URL:

<http://www.ibm.com/nc/pubs>

Recovering the flash image of a workstation

You can recover the flash image of a workstation that has a damaged flash image. This process is also known as reflashing the workstation. When you *recover* the flash image of a workstation, the recovery server reformats the CompactFlash card, and copies the recovery flash image to the workstation. Any configurations that you have made to the workstation are removed.

Note: You should only perform flash recovery when you have a workstation with a corrupt flash image.

You can recover the flash image of a workstation by using one of the following methods:

- “Using one workstation to recover the flash image of another workstation” on page 27
- “Using the Setup Utility to recover the flash image of a workstation” on page 29
- “Using the Thin Client Manager Operations Utility to recover the flash image of a workstation” on page 30

You need to specify the flash file that you want to use in the process, regardless of the method that you choose. See “Appendix E. Choosing a flash file” on page 55 for more information.

Using one workstation to recover the flash image of another workstation

You can use a peer workstation to perform a *peer flash recovery* on another workstation. The term *peer flash recovery* means that you use one workstation to recover the flash image of another workstation.

Note: You should only perform flash recovery when you have a workstation with a corrupt flash image.

You can perform a peer flash recovery, provided that the following statements are true:

- Both workstations that you are working with are of the same hardware type (example, N2800e)
- Both workstations have CompactFlash cards installed
- The recovery workstation has a CompactFlash card that is compatible from a language and memory perspective with the CompactFlash card on the workstation whose flash image you are recovering.

A peer flash recovery requires you to perform the following procedures:

1. “Enabling peer flash recovery on a workstation”
2. “Recovering the image on the peer-booted workstation” on page 28
3. “Disabling peer flash recovery on a workstation” on page 29

Enabling peer flash recovery on a workstation

The first step of peer flash recovery is to enable peer flash recovery on the workstation that you want to provide the peer recovery service. From the workstation that you want to provide the peer flash recovery, perform the following steps:

1. Power on the workstation.
2. Access the Configuration Tool:
 - a. Press and hold the following keys on the left side of the keyboard: **Shift + Ctrl + Alt**.
 - b. Hold these keys down for several seconds, until the Configuration Tool starts.

Note: If you are unable to enter the Configuration Tool, the workstation may not have access to the Configuration Tool. Refer to *IBM NetVista Thin Client Manager Operations Utility* (SA23-2813) for more information about granting and denying access to the Configuration Tool. This information is available at the following URL:

<http://www.ibm.com/nc/pubs>

3. In the Configuration Tool, click **Remote Management / Software Update**.
4. Click **Enable / Disable Peer Software Recovery**.
5. Select **Enable Peer Software Recovery**.
6. Click **OK**.

Do not exit the Configuration Tool at this time, as you will need to perform the procedure, “Disabling peer flash recovery on a workstation” on page 29 from this menu later.

7. Continue with the procedure, “Recovering the image on the peer-booted workstation”.

Recovering the image on the peer-booted workstation

The second step of peer flash recovery is recovering the image on the peer-booted workstation. The peer-booted workstation is the workstation whose flash image you are recovering. Follow these steps to recover the image:

1. Power on the *peer-booted* workstation.
2. Press **Esc** immediately after the following message disappears:
Hardware testing in progress . . .
3. Press a key to continue.
4. Follow the on-screen directions until you see the **Advanced configuration** menu (MENU03).
5. Select **Configure network settings**.
6. Press **Enter** to continue.
7. Set **Boot file source** to Network.
8. Verify that the following values are correct for your IP configuration:
 - Workstation IP Address
 - Gateway IP Address
 - Subnet Mask
9. Press **Enter** to continue.
10. Under **Boot file server IP address**, specify the IP address of the flash-booted workstation as the **First** option.
11. Under **Boot file server directory and file name**, specify the path and file name of the recovery kernel as the **First** option.
The following is an example of a probable path and file name:
/kernel.2200
12. Under **Boot file server protocol**, set **NFS** to **First**.
13. Press **F3** to save your settings and return to the **Advanced Configuration** menu.
14. Press **F10** to reboot the workstation.
After the flash-booted workstation successfully updates the flash image of the peer-booted workstation, the Configuration Tool appears on the display.

Note: The flash-booted workstation might take as long as 10 minutes to update the CompactFlash card of the peer-booted workstation. Do **not** power off either workstation during this time.
15. Use the **Simple configuration** menu of the Setup Utility to restore the workstation’s settings.
For information on using the Setup Utility, see “Using the Setup Utility to configure the workstation” on page 11.
16. Continue with the procedure, “Disabling peer flash recovery on a workstation” on page 29.

Disabling peer flash recovery on a workstation

The third step of peer flash recovery is to disable peer flash recovery on a workstation. Perform the following procedure from the workstation that you enabled to provide peer flash recovery:

1. From the **Remote Management / Software Update** menu, click **Enable / Disable Peer Software Recovery**.

The workstation should still display the **Remote Management / Software Update** menu from when you performed the procedure, “Enabling peer flash recovery on a workstation” on page 27.

2. Select **Disable Peer Software Recovery**.
3. Click **Ok**—>**Exit**.

Using the Setup Utility to recover the flash image of a workstation

You can use the NS Boot Setup Utility (hereafter referred to as Setup Utility) to recover the CompactFlash image of a workstation. If you have installed the IBM NetVista Thin Client Express Service Utility (hereafter referred to as Service Utility), you can use it as a source for recovery flash images.

Perform the following steps:

1. Power on the workstation whose flash image you want to recover.
2. Ensure that the Service Utility services have started on the Service Utility server. If you have not installed the Service Utility on a network server, you can use another workstation as your source for the recovery flash image. Continue with the next step.
3. Press **Esc** immediately after the following message disappears:
Hardware testing in progress . . .
4. Press a key to continue.
5. Follow the on-screen directions until you see the **Advanced Configuration** menu (MENU03).
6. Select **Configure Network Settings**.
7. Press **Enter** to continue.
8. Under **Network Priority**, specify the following:
 - Set **DHCP** to Disabled.
 - Set **BOOTP** to Disabled.
 - Set **Local (NVRAM)** to First.
9. Set **Boot file source** to Network.
10. Verify that the following values are correct for your IP configuration:
 - Workstation IP Address
 - Gateway IP Address
 - Subnet Mask
11. Press **Enter** to continue.
12. Under **Boot file server IP address**, specify the IP address of the Service Utility server as the **First** option. To use another workstation as your recovery flash source, enter the IP address of the recovery workstation.

Note: You need to perform the procedure, “Enabling peer flash recovery on a workstation” on page 27 before you can perform a peer flash recovery.

13. Under **Boot file server directory and file name**, specify this directory and file name as the **First** option:
`/NS/flashbase/x86/kernel.2200`
14. Under **Boot file server protocol**, set **NFS** to **First**.
15. Press **F3** to save your settings and return to the **Advanced Configuration** menu.
16. Press **F10** to reboot the workstation.
17. Specify the appropriate flash file, or BOM file, and press **Enter** to continue. For information on selecting the correct flash file, see “Appendix E. Choosing a flash file” on page 55.

Note: The workstation will not prompt you to specify a BOM file in the following instances:

- a. You are performing a peer flash recovery.
- b. The Service Utilities server administrator has already specified a BOM file to use for flash recovery.

Attention: Recovering the flash image of a workstation can take as long as 10 minutes. Do **not** power off the workstation until the flash recovery process is complete.

After the recovered workstation reboots, the Configuration Tool appears on the display.

18. Make any necessary changes to your configuration, and then click **Save and Restart**.

If you are interested in learning more about the Configuration Tool, see “Using the Configuration Tool to configure the workstation” on page 12.

Using the Thin Client Manager Operations Utility to recover the flash image of a workstation

You can use the Thin Client Manager Operations Utility to recover the flash image of a workstation. To find out how to perform this, and other workstation management tasks, refer to *IBM NetVista Thin Client Manager Operations Utility (SA23-2813)* for information about managing your Thin Client Express. This information is available at the following URL:

<http://www.ibm.com/nc/pubs>

Resolving hardware problems

This section provides information on verifying and resolving hardware problems.

If you cannot identify a hardware problem, you can request technical service and support by contacting IBM. You need to provide the machine type, model, and serial number of your NetVista thin client.

You can obtain additional service and support information at the following URL:

<http://www.ibm.com/nc/support>

Notes:

1. If your NetVista thin client is under warranty or a maintenance contract, contact IBM Service and Support to obtain a customer-replaceable unit (CRU). Refer to *IBM Network Station Hardware Warranty - Type 8363 and Type 8364 (SA23-2802)* for more information.
2. To resolve software errors, follow the instructions on the error message. For more information, contact IBM Service and Support.
3. Refer to the documentation for your monitor, PCI devices, serial devices, and USB devices for detailed information on resolving hardware problems that are associated with these devices.

Verifying hardware problems

Table 2 identifies possible hardware problem indications that can occur with the NetVista thin client during its startup sequence (see “Startup sequence” on page 9), or during normal operation.

Table 2. Hardware problem indications

Startup Checkpoints	Visible hardware failure	LED indications (system LED)	Audio beep sequences	Error codes and text messages (NSBxxxx)
Power on	X	X	X	
Monitor initialization	X			X
Keyboard initialization	X			X
Welcome screen	X			X

If you experience any hardware problem indications, you need to verify that an easily avoidable problem is not causing the hardware problem indication. Record any hardware problem indications and a description of the problem, and then proceed with the instructions below.

These instructions ensure that you start resolving any hardware problems by resetting the power to your hardware.

To determine the cause of NetVista thin client hardware problems, follow these steps to reset the power to your hardware:

- ___ 1. Power off the NetVista thin client.

- ___ 2. Unplug the power cable from the electrical outlet.
- ___ 3. Ensure that you properly connected all devices to the NetVista thin client. See “Connecting your hardware” on page 8 for more information.
- ___ 4. Plug the NetVista thin client power cable into a properly grounded, working electrical outlet.
- ___ 5. Power on the NetVista thin client.
- ___ 6. Wait for the IBM NetVista thin client screen to appear on your monitor.
 - If the IBM NetVista thin client screen appears, and the NetVista thin client does not indicate any hardware problems during power-on, you do not have a hardware problem.
 - If the NetVista thin client indicates a hardware problem, record any problem indications and a description of the problem. Consult Table 3 with your hardware problem information.

Table 3. Hardware problem resolution information

Hardware problem indications	Where to find information
Visible hardware failure	“Visible hardware failure”
Audio beep sequences	“Audio beep sequences” on page 34
LED indications	“LED indications” on page 35
Error codes and text messages	“Error codes and text messages” on page 36

Visible hardware failure

You experience visible hardware failure during normal operation when a device that is attached to your logic unit fails to function properly. Visible hardware failure includes the following:

- A device that is attached to your logic unit fails to function at all.
For example:
 - Your mouse cursor stops moving.
 - Your monitor displays a blank screen.
 - Characters do not display on your monitor when you type.
- A device that is attached to your logic unit does not function properly.
For example:
 - Your monitor displays unreadable screens.
 - Your mouse cursor does not move smoothly.
 - Some keys on your keyboard do not respond correctly.

If your NetVista thin client hardware has a visible hardware failure, consult Table 4. Contact your technical support if these steps do not resolve the problem.

Table 4. Visible hardware failure

Symptom	What you should do
Logic Unit	

Table 4. Visible hardware failure (continued)

Symptom	What you should do
<p>The system LED does not light up when you press the white power button to power on the NetVista thin client.</p>	<ol style="list-style-type: none"> 1. Verify that you plugged the power cable into a working electrical outlet. 2. Verify that the power cable LED indicates a solid green color. 3. Reset power to the NetVista thin client by pressing the white power button. 4. If the system LED does not work, any of the following devices may be defective: <ul style="list-style-type: none"> • Power cable Verify that the power cable LED indicates a solid green color. • Power cable <p>Substitute a properly working device for a defective device. Repeat the previous steps. See “Appendix A. Replacing hardware parts” on page 41 for more information.</p> 5. If the system LED still does not work, you may need to replace the NetVista thin client logic unit. See “Appendix A. Replacing hardware parts” on page 41 for more information on replacing a defective mouse.
Monitor	
<ul style="list-style-type: none"> • The monitor displays a blank screen. • The monitor displays unreadable screens. 	<p>If the problem persists after you have verified the monitor cable connections, or after you have substituted a properly working monitor, refer to the documentation for your monitor for troubleshooting information.</p>
Keyboard	
<ul style="list-style-type: none"> • The arrow keys do not respond when you press them. • Characters do not display on the monitor when you type. 	<ol style="list-style-type: none"> 1. Verify that you connected the keyboard cable properly to the NetVista thin client. 2. If the problem persists, the keyboard may be defective. <ul style="list-style-type: none"> • Substitute a properly working keyboard, and repeat the previous steps. • See “Appendix A. Replacing hardware parts” on page 41 for more information on replacing a defective keyboard. 3. If the keyboard still does not work, you may need to replace the NetVista thin client logic unit. See “Appendix A. Replacing hardware parts” on page 41 for more information on replacing a defective logic unit.
Mouse	

Table 4. Visible hardware failure (continued)

Symptom	What you should do
<ul style="list-style-type: none"> • The mouse cursor stops moving; the mouse does not function at all. • The mouse cursor does not move smoothly. 	<ol style="list-style-type: none"> 1. Verify that you connected the mouse cable properly to the NetVista thin client keyboard. 2. If the mouse does not work, any of the following devices may be defective: <ul style="list-style-type: none"> • Mouse • Keyboard <p>Substitute a properly working device for a defective device. Repeat the previous steps. See “Appendix A. Replacing hardware parts” on page 41 for more information.</p> 3. If the mouse still does not work, you may need to replace the NetVista thin client logic unit. See “Appendix A. Replacing hardware parts” on page 41 for more information on replacing the defective logic unit.

Audio beep sequences

The NetVista thin client hardware utilizes both audio and visual alerts when reporting hardware problems. In the event of a hardware problem, the NetVista thin client emits audio beeps before your monitor initializes. After your monitor initializes, error codes and text messages appear on the screen (see “Error codes and text messages” on page 36).

Audio beep sequences can include short beeps, long beeps, and brief silent periods. Table 5 on page 35 defines the possible audio beep sequences that can occur when a hardware problem exists.

To verify that a NetVista thin client hardware problem exists, ensure that you complete the instructions in “Verifying hardware problems” on page 31.

If the NetVista thin client is not functioning properly, and it is emitting audio beep sequences, consult Table 5 on page 35. Contact your technical support if these steps do not resolve the problem.

Notes:

1. These beep sequences are in a numeric format which indicates the sequence of the audio output.
2. Audio beep sequences do not occur after the monitor initializes.

Table 5. Audio beep sequences

Symptom	What you should do
The NetVista thin client emits a 1-3-1 beep sequence, and the system LED is flashing amber.	<p>Memory error</p> <ol style="list-style-type: none"> 1. Check or replace the memory card. Refer to “Appendix B. Hardware maintenance procedures” on page 45 for instructions. 2. Verify that you properly connected the network cable to the NetVista thin client network connector. 3. Power on the NetVista thin client. 4. If the problem persists, you may need to replace the NetVista thin client logic unit. Refer to “Appendix A. Replacing hardware parts” on page 41 for information.
The NetVista thin client emits a 2-3-2 beep sequence, and the system LED is flashing amber.	<p>Video memory error</p> <ol style="list-style-type: none"> 1. Verify that you properly connected the network cable to the NetVista thin client network port. 2. Power on the NetVista thin client. 3. If the problem persists, you may need to replace the NetVista thin client logic unit. Refer to “Appendix A. Replacing hardware parts” on page 41 for information.

LED indications

The LED indicators of the following devices maintain a solid green color during normal operation:

- Logic unit (system LED and network status LED)
- Monitor
- Keyboard

The network status LED indicates a solid green color during normal operation. The network status LED indicates a flashing amber color, during network activity.

The system LED quickly flashes from amber to green during a normal power-on. The system LED indicates hardware problems in the following ways:

- The flashing green indications
- The flashing amber indications
- Steady amber indications
- Failure to function

To verify that a NetVista thin client hardware problem exists, ensure that you complete the instructions in “Verifying hardware problems” on page 31.

If the NetVista thin client is not functioning properly, and the LED indicators indicate anything other than a solid green color, consult Table 6. Contact your technical support if these steps do not resolve the problem.

Table 6. LED indications

Symptom	What you should do
	System LED

Table 6. LED indications (continued)

Symptom	What you should do
The system LED fails to function after power on.	<ol style="list-style-type: none"> 1. Verify that you plugged the power cable into a working electrical outlet. 2. Press the white power button to reset power to the NetVista thin client. 3. If the system LED does not work, the power cable may be defective. Substitute a properly working power cable, and then repeat the steps. Contact your reseller, or IBM, to request a replacement part (see “Replacing parts other than the N2800e CompactFlash card” on page 42). 4. If the system LED still does not work, you may need to replace the NetVista thin client logic unit. Contact your reseller, or IBM, to request a replacement part (see “Replacing parts other than the N2800e CompactFlash card” on page 42).
A power interruption during a software update occurs. When you power on the NetVista thin client, the system LED shows a solid green color, or a flashing amber color, and the monitor does not display any screens.	The software on the NetVista thin client may be damaged. Contact IBM Service and Support, and refer to “Appendix D. Recovering the boot block image” on page 53 for information on recovering the software on the NetVista thin client.
The system LED shows a solid amber color, or a flashing amber color.	<ol style="list-style-type: none"> 1. Press the white power button to reset power to the NetVista thin client. 2. If the system LED still shows a solid amber color, or a flashing amber color, you may need to replace the NetVista thin client logic unit. Contact your reseller, or IBM, to request a replacement part (see “Replacing parts other than the N2800e CompactFlash card” on page 42).
The system LED flashes amber once shortly after power off.	The NetVista thin client hardware automatically enables Wake-On-LAN (WOL). This is not an indication of a hardware problem.
Monitor LED	
The monitor LED fails to function after power on.	If the problem still persists after you verified the monitor cable connections, or after you substituted a properly working monitor, refer to the documentation for your monitor for more information.
The monitor LED shows a solid amber color, or a flashing amber color.	If the problem still persists after you verified the monitor cable connections, or after you substituted a properly working monitor, refer to the documentation for your monitor for more information.

Error codes and text messages

Error codes and text messages can appear on the bottom of your screen during the startup sequence of the NetVista thin client. **NSBxxxx** error codes and text messages indicate only hardware problems.

To verify that a NetVista thin client hardware problem exists, ensure that you complete the instructions in “Verifying hardware problems” on page 31.

If the NetVista thin client is not functioning properly, and an error code or text message appears on your screen, consult Table 7. Contact your technical support, reseller, or IBM, if these steps do not resolve the problem.

Table 7. Error codes and text messages

Symptom	What you should do
An error code or text message appears on the screen.	<ol style="list-style-type: none"> 1. Record any error messages, audio beep sequences, or LED indications, and a description of the problem. 2. Perform any actions indicated within the error message. 3. Contact your technical support.
A boot interruption screen appears.	Press F10 to reboot the NetVista thin client.

Table 8 defines the error messages that can appear when you power on the NetVista thin client. This table provides information that you must only follow under the direction of the IBM Service and Support team.

Table 8. NSBxxxx error codes and text messages

Error code	Error message	What you should do
General messages (NSB0xxxx)		
NSB00030	Canceled by user.	Press any key to enter the NS Boot utility.
Battery messages (NSB01xxx)		
NSB01500	Battery dead.	Replace the lithium battery (see "Appendix B. Hardware maintenance procedures" on page 45).
Main memory messages (NSB10xxx)		
NSB11500	On board memory failure.	Ensure that the memory is installed properly, or replace memory (see "Appendix B. Hardware maintenance procedures" on page 45).
NSB11510	Slot %d memory failure.	Ensure that the memory is installed properly, or replace the memory (see "Appendix B. Hardware maintenance procedures" on page 45).
Non-volatile memory messages (NVRAM) (NSB11xxx)		
NSB12500	Checksum failure for nonvolatile memory.	Re-enter NS Boot configuration data, if different from the default values.
NSB12510	Not able to access nonvolatile memory.	Replace the thin client logic unit (see "Appendix A. Replacing hardware parts" on page 41).
NSB12520	Setting nonvolatile memory to manufacturing defaults.	Re-enter NS Boot configuration data, if different from the default values.
NSB12530	Detected reset jumper.	The password has been cleared,.
NSB12540	New nonvolatile memory structure detected.	Re-enter NS Boot configuration data, if different from the default values.
Audio messages (NSB21xxx)		

Table 8. NSBxxxx error codes and text messages (continued)

Error code	Error message	What you should do
NSB21500	Audio failure.	Replace the thin client logic unit (see “Appendix A. Replacing hardware parts” on page 41).
Input, keyboard and mouse messages (NSB3xxxx, NSB31xxx, and NSB32xxx)		
NSB30500	No input device detected. NS Boot will continue in 10 seconds.	Check the keyboard and mouse cable connections.
NSB31500	Keyboard did not respond.	Check the keyboard cable connection.
NSB31510	Keyboard controller did not respond.	Check the keyboard and mouse cable connections. If the symptom remains, replace the thin client logic unit (see “Appendix A. Replacing hardware parts” on page 41).
NSB31520	Keyboard was not recognized.	Check the keyboard cable connection.
NSB32500	Mouse did not respond.	Check the mouse cable connection.
USB messages (NSB4xxxx)		
NSB40500	USB failure.	Disconnect any USB devices from the thin client and restart the system. If the symptom remains, replace the thin client logic unit (see “Appendix A. Replacing hardware parts” on page 41).
NSB40510	USB initialization failure.	Disconnect any USB devices from the thin client and restart the system. If the symptom remains, replace the thin client logic unit (see “Appendix A. Replacing hardware parts” on page 41).
CompactFlash card messages (NSB51xxx)		
NSB51500	File not found on flash card.	Check the contents of the CompactFlash card.
NSB51510	Cannot close file on flash card.	Check the contents of the CompactFlash card.
Ethernet messages (NSB62xxx)		
NSB62500	Line speed automatic negotiation failed.	Verify that you connected the network cable to the thin client correctly.
NSB62510	No network device found.	Replace the thin client logic unit (see “Appendix A. Replacing hardware parts” on page 41).
Network priority messages (NSB7xxxx)		
NSB70500	DHCP, BOOTP, and Local (NVRAM) network priority not set.	Verify that at least one network priority is enabled in the NS Boot utility.
DHCP messages (NSB71xxx)		
Most errors associated with DHCP are server configuration errors, contact the system administrator and report your error.		

Table 8. NSBxxxx error codes and text messages (continued)

Error code	Error message	What you should do
NSB71509	DHCP option %d boot server name %s failed DNS.	Verify that the DHCP server settings are correct.
NSB71515	Missing DHCP option %d from server.	Verify that the DHCP server settings are correct.
NSB71525	Missing DHCP client IP address.	Verify that the DHCP server settings are correct.
NSB71535	Missing DHCP client directory and file name.	Verify that the DHCP server settings are correct.
NSB71545	DHCP OFFER XID different than DHCP DISCOVER XID.	Verify that the DHCP server settings are correct.
NSB71555	DHCP options exceed the maximum allowable DHCP option length.	Verify that the DHCP server settings are correct.
NSB71605	DHCP offer from server %s not valid.	Verify that the DHCP server settings are correct.
BOOTP messages (NSB72xxx)		
NSB72505	BOOTP options exceed the maximum allowable BOOTP option length.	Verify that the BOOTP server settings are correct.
Network communication messages (NSB8xxxx)		
NSB80509	Destination unreachable, return code ~%d.	Verify that there are no problems with the network, and restart the thin client.
NSB80519	Failed ICMP mask request.	Verify that there are no problems with the network, and restart the thin client.
NSB80529	Failed ICMP router solicitation.	Verify that there are no problems with the network, and restart the thin client.
NSB80539	Domain Name Server (DNS) error, return code %d.	Verify that there are no problems with the network, and restart the thin client.
NSB80549	Cannot fragment data packet, data not sent.	Verify that there are no problems with the network, and restart the thin client.
NSB80550	Transfer terminated by user.	Restart the thin client.
TFTP messages (NSB81xxx)		
NSB81509	Time-out waiting for TFTP reply.	Restart the thin client. If this does not solve the problem, verify that you connected the network cable to the thin client.
NSB81519	TFTP error - %d %s.	
Boot file server messages (NSB83xxx)		
NSB83509	Unable to load file via boot file server protocol.	Ensure that the boot protocol agrees with your server settings in the NS Boot utility.
NSB83519	Cannot access boot file from any server.	Verify your configuration settings in the NS Boot utility, and confirm the server configuration.
NSB83529	Cannot contact boot file server ~%s.	Verify that the boot server settings are configured correctly.

Table 8. NSBxxxx error codes and text messages (continued)

Error code	Error message	What you should do
NSB83539	Cannot PING boot server ~ %s.	Verify your configuration settings in the NS Boot utility, and confirm the server configuration.
NSB83549	Unable to open file.	Confirm the server configuration.
NSB83560	Boot file name or directory not valid.	Verify your configuration settings in the NS Boot utility, and confirm the server configuration.
NSB83579	Failed to boot after 1 attempt.	Verify your configuration settings in the NS Boot utility, and confirm the server configuration.
NSB83589	Failed to boot after %d attempts.	Verify your configuration settings in the NS Boot utility, and confirm the server configuration.
NSB83590	Unrecognized boot file server protocol.	Verify your configuration settings in the NS Boot utility.
NSB83600	Boot file server protocol not specified.	Verify your network configuration settings in the NS Boot utility.
NSB83619	Address resolution failed, boot file server ~ %s.	Verify your configuration settings in the NS Boot utility, and confirm the server configuration.
Gateway messages (NSB84xxx)		
NSB84509	Gateway address not valid.	Verify your network configuration settings in the NS Boot utility.
NSB84519	Address resolution failed, gateway ~ %s.	Verify your network configuration settings in the NS Boot utility.
Client IP address messages (NSB85xxx)		
NSB85509	Duplicate IP address ~ %s, that is owned by %s.	Verify your network configuration settings in the NS Boot utility, and the DHCP or BOOTP server configuration settings.
NSB85519	IBM Network Station IP address not valid.	Verify your network configuration settings in the NS Boot utility.
Subnet mask messages (NSB86xxx)		
NSB86509	Subnet mask not valid.	Verify your network configuration settings in the NS Boot utility.
IP address messages (NSB87xxx)		
NSB87509	Address resolution failed, IP address ~ %s.	Verify your network configuration settings in the NS Boot utility.
NSB87519	Address resolution failed. IP address ~ %s not valid.	Verify your network configuration settings in the NS Boot utility.
NSB87529	IP address %s not in ARP cache.	Verify your network configuration settings in the NS Boot utility.
Remote packet messages (NSB88xxx)		
NSB88500	Stopping DLL packet replication.	Reload the factory default settings on the thin client, and then configure the network settings in the NS Boot utility.

Appendix A. Replacing hardware parts

You can order IBM replacement parts for the thin client. Contact IBM or your reseller to order warranty parts and non-warranty parts. IBM provides warranty service without charge for parts during the warranty period on an exchange basis only.

To replace a logic unit, the customer must transfer features, such as memory DIMMs, CompactFlash cards, and any optional PCI adapter cards to the replacement assembly. If customers do not transfer their features, the replacement units cannot operate properly. See “Safety notices” on page v for information about handling Customer Replaceable Unit (CRU) parts.

IBM delivers CRUs to the customers for exchange, and customers return defective parts to IBM under the basic service offering. Customers should return all defective logic units without the cover set, CompactFlash card, support base or memory DIMMs (see “Returning hardware parts” on page 44 for more information). For upgraded service offerings, a service representative delivers replacement parts, transfers features, and returns defective parts to IBM.

See “Resolving hardware problems” on page 31 to determine whether or not it is necessary to replace the thin client logic unit or any other parts.

Replacing the N2800e Thin Client Express CompactFlash card

IBM replaces a defective logic unit drawer as a complete assembly. This assembly does not include the N2800e Thin Client Express CompactFlash card. Refer to Table 9 to determine the correct CompactFlash card to order for your language preference. Warranty service terms and conditions by country apply.

Table 9. Thin Client Express logic units

Description	Model	Part number
CompactFlash cards for N2800e (Model Cxx)		
CompactFlash Card for Model Cxx	CUS (US English), CAP (Asia Pacific), CLS (LA Spanish), CCF (Canadian French), CBP (Brazilian Portuguese)	31L5281
CompactFlash Card for Model Cxx	CUI (US English ISO 9995), CUK (UK English), CEU (European), CGE (German), CFR (French), CSW (Swedish/Finnish), CDK (Danish), CNO (Norwegian), CND (Dutch)	31L5282
CompactFlash Card for Model Cxx	CIL (Icelandic), CSG (Swiss German/French/Italian), CIT (Italian), CLE (Luxembourg), CSP (Spanish), CBE (Belgian Dutch/English), CPO (Portuguese)	31L5283

Replacing parts other than the N2800e CompactFlash card

Use the following tables to determine the correct part number for replacement parts. Warranty service terms and conditions by country apply.

Table 10. Type 8364 thin client replacement parts

Description	Country	Part number
Logic unit and associated parts		
Logic unit (includes internal power supply)	All Countries	41L5339
Cover set	All Countries	41L4965
Base (mounting stand)	All Countries	41L4981
Lithium Battery (3 Volt)	All Countries	33F8354
Internal Power Supply (115V-230V)	All Countries	94H1254
Memory		
Note: This thin client accepts 168 pin, 3.3 V, gold tab, unbuffered, non-parity, and 100MHz SDRAM DIMM memory.		
Memory (32 MB SDRAM DIMM)	All Countries	01K1146
Memory (64 MB SDRAM DIMM)	All Countries	01K1147
Memory (128 MB SDRAM DIMM)	All Countries	01K1148
Mouse		
Mouse (two button)	All Countries	76H0889
Keyboards		
Keyboard	Belgian UK	37L0857
Keyboard	Brazilian Portuguese	07L9450
Keyboard	Canadian French	37L0852
Keyboard	Danish	37L0860
Keyboard	French	37L0862
Keyboard	French Canadian	37L0910
Keyboard	Finnish	37L0877
Keyboard	German	37L0863
Keyboard	Italian	37L0868
Keyboard	Latin America (Spanish)	37L0853
Keyboard	Norwegian	37L0869
Keyboard	Spanish	37L0876
Keyboard	Swedish	37L0877
Keyboard	Swiss (French and German)	37L0878
Keyboard	UK English	37L0881
Keyboard	US English ISO9995	37L0883
Keyboard	US English	37L0851

Table 11. Detachable power cables

Voltage Selection	Plug	Receptacle	Country	Part number
Detachable power cables				

Table 11. Detachable power cables (continued)













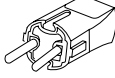







Voltage Selection	Plug	Receptacle	Country	Part number
230V			Argentina, Australia, New Zealand	13F9940
230V			Abu Dhabi, Austria, Belgium, Bulgaria, Botswana, Egypt, Finland, France, Germany, Greece, Iceland, Indonesia, Korea (South), Lebanon, Luxembourg, Netherlands, Norway, Portugal, Saudi Arabia, Spain, Sudan, Sweden, Turkey, Yugoslavia	13F9978
115V			Bahamas, Barbados, Bolivia, Brazil, Canada, Costa Rica, Dominican Republic, El Salvador, Ecuador, Guatemala, Guyana, Haiti, Honduras, Jamaica, Japan, Netherlands Antilles, Panama, Peru, Philippines, Taiwan, Thailand, Trinidad, Tobago, U.S.A. (except Chicago), Venezuela	1838574
115V			Bahamas, Barbados, Bermuda, Bolivia, Brazil, Canada, Cayman Islands, Colombia, Costa Rica, Dominican Republic, Ecuador, El Salvador, Guatemala, Guyana, Haiti, Honduras, Jamaica, Japan, Korea (South), Mexico, Netherlands Antilles, Nicaragua, Panama, Peru, Philippines, Puerto Rico, Saudi Arabia, Suriname, Trinidad, Taiwan, U.S.A	6952301
230V			Bahrain, Bermuda, Brunei, Channel Islands, Cyprus, Ghana, Hong Kong, India, Iraq, Ireland, Jordan, Kenya, Kuwait, Malawi, Malaysia, Nigeria, Oman, People's Republic of China, Qatar, Singapore, Tanzania, Uganda, United Arab Emirates (Dubai), United Kingdom, Zambia	14F0032
230V			Bangladesh, Burma, Pakistan, South Africa, Sri Lanka	14F0014

Table 11. Detachable power cables (continued)

Voltage Selection	Plug	Receptacle	Country	Part number
230V			Denmark	13F9996
230V			Israel	14F0086
230V			Chile, Ethiopia, Italy	14F0068
230V			Liechtenstein, Switzerland	14F0050

Returning hardware parts

You may not need to return all defective items to IBM. Always check the replacement part packaging for any instructions regarding the return of defective parts.

To return a defective part to IBM, pack the defective part in the packaging container of the replacement part.

Note: Customers must not ship features, such as memory DIMMs, CompactFlash cards, or PCI adapter cards with defective logic units that they are returning to IBM. It is not possible for IBM to return these features to customers.

If customers do not follow IBM shipping instructions, they may get charges for any damage to a defective part. IBM covers shipping costs on all warranted hardware and maintenance agreement hardware. Replacement parts become the customer's property in exchange for the defective parts, which become the property of IBM.

For information on ordering thin client parts, refer to "Replacing parts other than the N2800e CompactFlash card" on page 42.

Appendix B. Hardware maintenance procedures

Removing the logic unit to install parts

Read Safety notices, and “Handling static-sensitive devices” on page vi before continuing.

1. Turn off the power supply switch **A**.
2. Disconnect all cables from the thin client.
3. Hold the thin client cover assembly, lift latch **B**, and pull the logic unit **C** out.
4. Carefully lay the logic unit down with the internal components facing up. You are now ready to perform the installation procedures provided in this chapter.
5. Complete the procedure, “Reassembling the thin client” when you are finished installing components in the logic unit.

Reassembling the thin client

Read Safety notices, and “Handling static-sensitive devices” on page vi before continuing.

1. To reassemble the thin client, carefully slide the logic unit **C** into the cover assembly while depressing the slide stop **D**.
2. Slide the logic unit completely into the cover assembly, until the latch **B** is engaged.
3. Perform steps 1 through 5 of the procedure, “Connecting your hardware” on page 8.

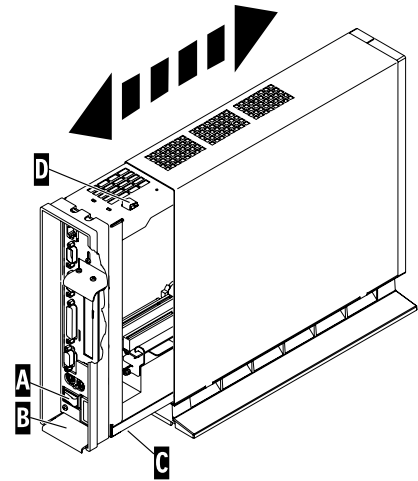

RBBSS500-5

Replacing a CompactFlash card

Read “Caution notices” on page vi, and “Removing the logic unit to install parts” on page 45 before continuing.

1. Uninstall the N2800e thin client CompactFlash card by pulling it out of the connector **B**.
2. Match the grooves on the sides of the CompactFlash card that you are installing (**A**) to the inside of the connector **B**.
3. Install the CompactFlash card **A** into the connector **B**.

Note: Do not force the card into the connector, as it will damage both the thin client, and the CompactFlash card.

4. See “Reassembling the thin client” on page 45.

Installing an optional PCI card

Complete the procedure, “Removing the logic unit to install parts” on page 45 before performing the following Peripheral Component Interconnect (PCI) procedure.

1. Loosen the thumb screw **C** to slide the plate **E** up.
2. Remove the PCI slot covers **F**.
3. From inside the logic unit, install the PCI card down into both the slot, and the PCI socket **G**.

Note: Inserting the first PCI card into the socket closest to the logic board makes installing a second PCI card easier.

4. Install PCI slot covers over any empty slots.
5. Slide the plate **E** down until the tabs **D** secure the PCI slot covers **F** firmly into place.
6. Tighten the thumb screw **C**.
7. See “Reassembling the thin client” on page 45.

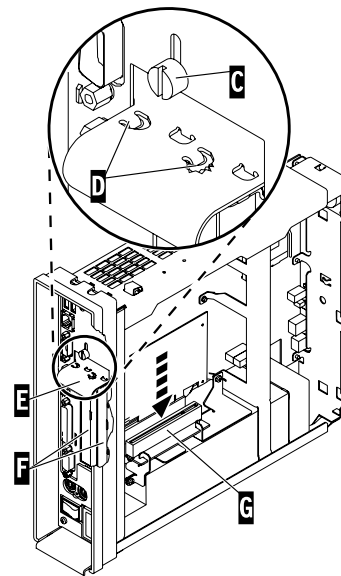
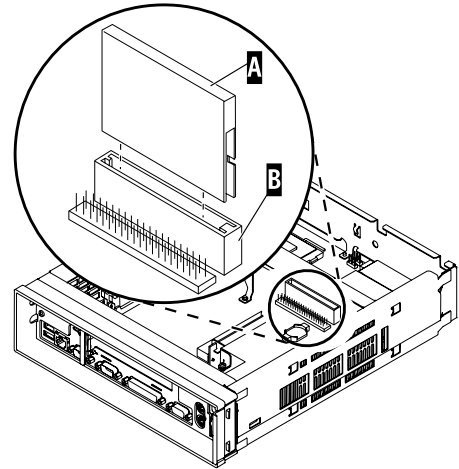

RBBSS501-5

Exchanging the memory

See “Resolving hardware problems” on page 31 to determine whether or not it is necessary to replace the logic unit, or any other parts. For information on ordering thin client hardware parts, refer to “Replacing parts other than the N2800e CompactFlash card” on page 42. Complete the procedure, “Removing the logic unit to install parts” on page 45 before performing the following Dual Inline Memory Module (DIMM) procedures:

1. To remove a DIMM from the logic unit, press the two tabs **B** located at each end of the DIMM **A** out and down.
2. To install a DIMM into the logic unit, align the notches on the bottom of the DIMM **A** with the notched areas on the memory socket.
3. Press down firmly on the center of DIMM **A** until the memory socket tabs **B** flip up.
4. See “Reassembling the thin client” on page 45.

Exchanging the lithium battery

Read “Caution notices” on page vi, and see “Removing the logic unit to install parts” on page 45 before continuing.

1. To remove the battery, place your thumb on the battery **C** and lift it up with your index finger.
2. Dispose of the used battery according to your local regulations.
3. Install the new battery into the battery socket **D**, with the “+” sign facing up.
4. See “Reassembling the thin client” on page 45.

Note: If you receive an error message on your screen after performing this procedure, see “Resolving hardware problems” on page 31.

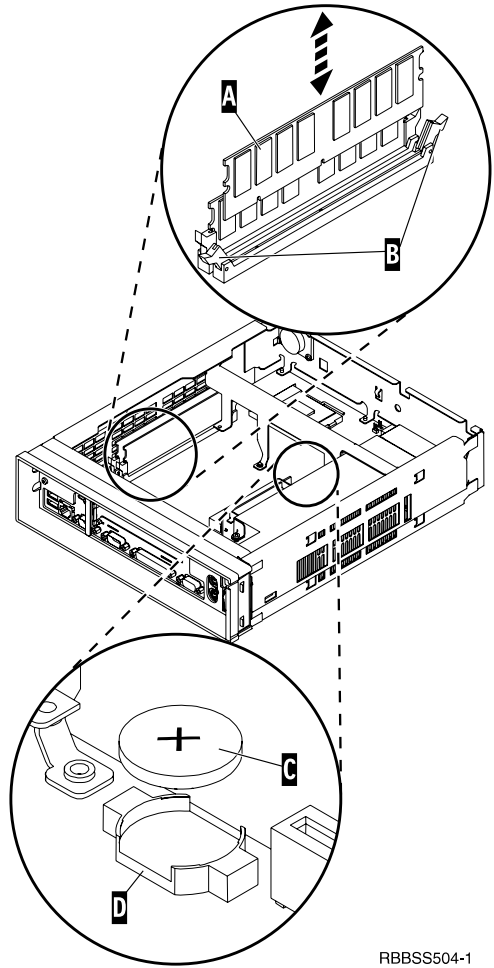

RBBSS504-1

Removing the power supply:

Notes:

1. Only IBM-authorized personnel should remove the power supply.
2. You will need a Phillips head screwdriver for the following procedure.
 1. Complete the procedure, "Removing the logic unit to install parts" on page 45 before continuing.
 2. Disconnect the power supply connector **A** from the logic board.
Pinch the top of the power supply connector as you disconnect it from the logic board. This releases the power supply connector latch.
 3. Remove the two screws **B** attaching the support plate **C** to the power supply **D**.
 4. Pull the support plate **C** out of the logic unit and set it aside.
 5. Remove the three screws **E** attaching the power supply to the logic unit.
 6. Push the power supply toward the front of the logic unit until it stops.
 7. Carefully remove the power supply from the logic unit.
 8. Continue with the procedure, "Installing the power supply" on page 49.

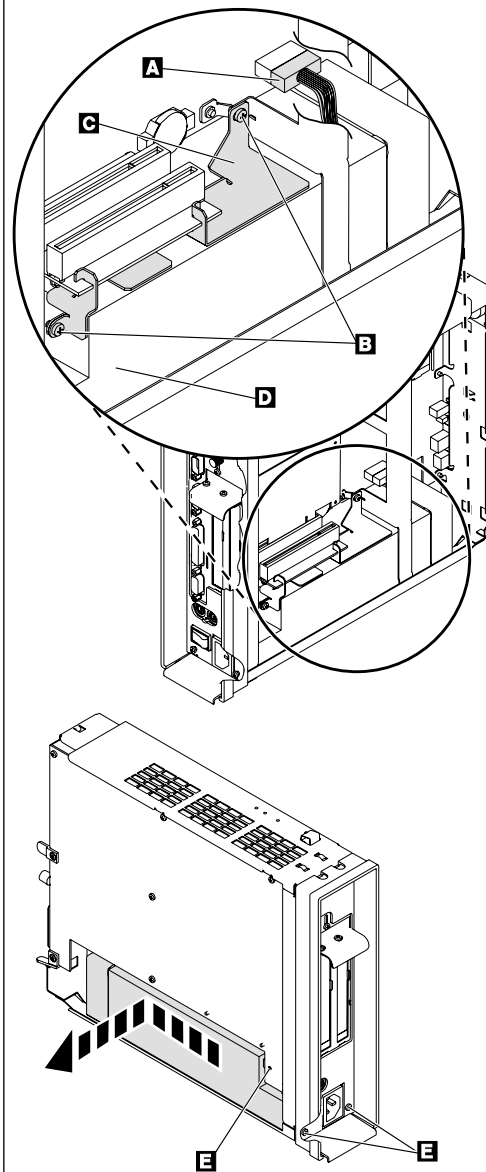

RCBN189-2

Installing the power supply:

1. Carefully install the power supply into the logic unit so that the power supply fan assembly faces the front of the logic unit.
2. Slide the power supply toward the back of the logic unit until it stops.
3. Make sure that the power supply is seated correctly, and firmly into the logic unit.
4. Secure the power supply with the three Phillips head screws **A** removed during the power supply removal procedure.
5. Slide the support plate **B** into place between the riser card and power supply.
6. Secure the support plate with the two Phillips head screws **C** removed during the power supply removal procedure.
7. Install the power connector **D** into its socket on the logic board.
8. See “Reassembling the thin client” on page 45.

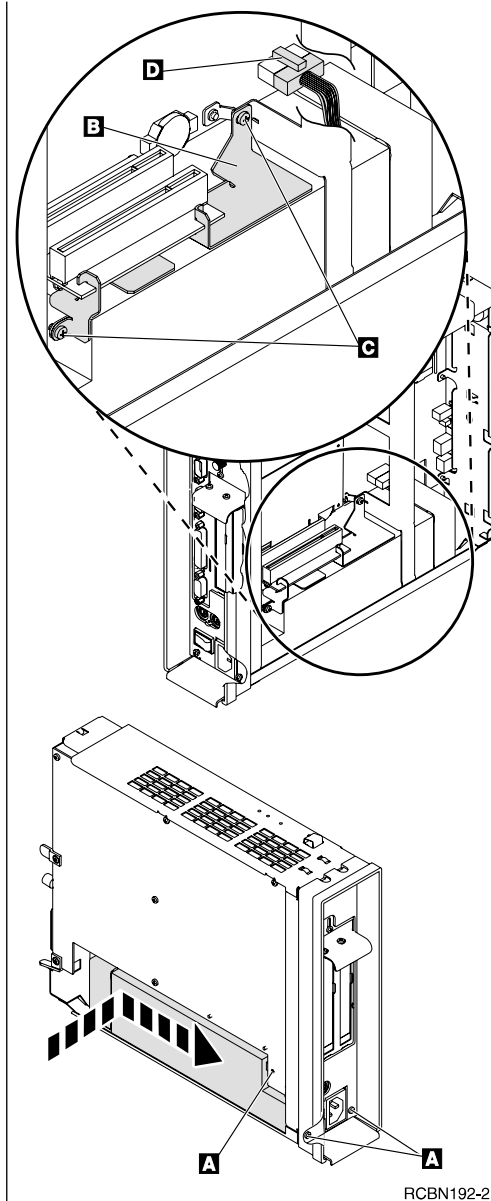

Appendix C. Setting the thin client voltage for your location

Selecting the voltage for your location:

Note: All N2800e thin clients are preset to the 230V setting when manufactured.

1. Power off the N2800e thin client.
2. Remove the base from the N2800e thin client.
3. Locate the voltage selector switch **A**.
4. Use a pen, or similar object, to slide the switch to the correct setting for your location (see **Voltage selection** in Table 11 on page 42).
5. Slide the base back on to the N2800e thin client.
6. Power on the N2800e thin client.

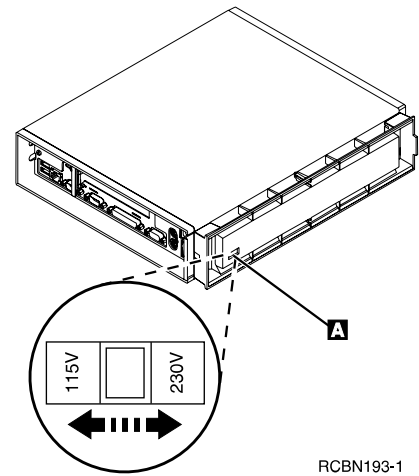

Appendix D. Recovering the boot block image

This section provides instructions that should be followed only under the direction of the IBM Service and Support team. Use these instructions only if you encountered a power interruption during a software update.

Read “Safety notices” on page v before you continue with these instructions.

Creating a recovery CompactFlash card:

This procedure creates a copy of the thin client firmware (hereafter referred to as flash image). You need a CompactFlash card to complete this procedure. **Note:** Once you create a recovery CompactFlash card for an N2800e (machine type 8364) thin client, it can only be used to re-flash an N2800e thin client.

1. Complete the procedure, “Removing the logic unit to install parts” on page 45 before continuing.
2. Insert the CompactFlash card into the connector.
3. Move the jumpers into configuration **2**.

Note: All systems ship with jumpers installed in configuration **1**.

4. Power on the thin client.
This requires you to reconnect the power cable to the logic unit.
5. Wait for the system LED to flash green.
Note: If the system LED flashes amber, the image was not created. Repeat the procedure, or see “Resolving hardware problems” on page 31 for problem determination.
6. Power off the thin client.
7. Remove the CompactFlash card and store in a safe place.
8. Move the jumpers back into the default configuration **1**.
If you do not move the jumpers back into configuration **1**, your thin client may not function properly.
9. See “Reassembling the thin client” on page 45.

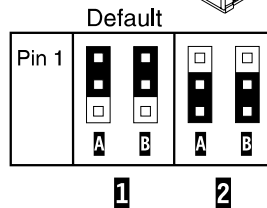
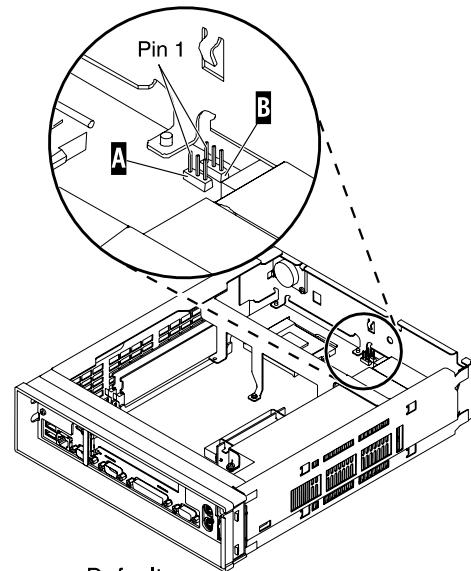

RBBST503-2

Recovering the flash image

You need a CompactFlash card with an N2800e (machine type 8364) flash image to complete this procedure. See “Creating a recovery CompactFlash card” on page 53 to create a recovery CompactFlash card.

1. Complete the procedure, “Removing the logic unit to install parts” on page 45 before continuing.
2. Insert the CompactFlash card into the CompactFlash connector.
3. Move the jumpers into configuration **2**.
Note: All systems ship with jumpers installed in configuration **1**.
4. Power on the thin client.
This requires you to reconnect the power cable to the logic unit.
5. When the flash image has been re-flashed, the LED will flash green.
If the system LED is amber, or flashes amber, the flash image cannot be re-flashed. Try a different CompactFlash card with the N2800e (machine type 8364) flash image stored on it, or recreate the recovery CompactFlash card (see “Creating a recovery CompactFlash card” on page 53), and then repeat this procedure. If you are still unable to recover the flash image, replace the logic unit (see “Replacing the N2800e Thin Client Express CompactFlash card” on page 41).
6. Power off the system.
7. Remove the CompactFlash card from the connector.
8. Move the jumpers back into the default configuration **1**.
If you do not move jumpers back into configuration **1**, your thin client may not function properly.
9. See “Reassembling the thin client” on page 45.

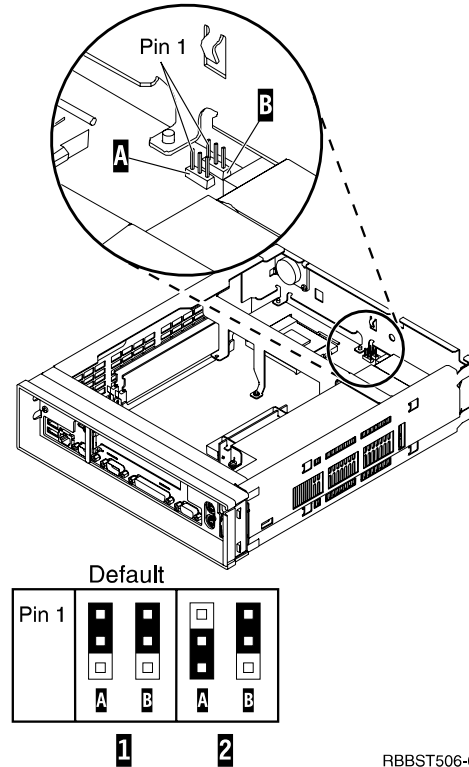

Appendix E. Choosing a flash file

Regardless of which method you use to update the flash image of a workstation, you may need to specify the flash file to use. These files, which are sometimes called Bill of Material (BOM) files, contain a list of files that make up a flash image.

When reflashing your flash card, you must specify which image you want.

Note: The first three images listed below include Netscape browser and PPP Dialer support.

Table 12. Flash files (also referred to as BOM files)

BOM file	Languages supported
NS-x86-0000-e-032-020-01.BOM	US English, LA Spanish, Canadian French, Brazilian Portuguese, UK English, French, Swiss French, Belgian French
NS-x86-0000-e-032-020-02.BOM	US English, German, French, Swedish, Finnish, Danish, Norwegian, Dutch, UK English, Swiss German, Belgian Dutch, Canadian French, Swiss French, Belgian French
NS-x86-0000-e-032-020-03.BOM	US English, Swiss German, Spanish, Belgian French, Swiss French, Swiss Italian, Italian, Belgian Dutch, Portuguese, UK English, German, Dutch, French, Canadian French
NS-x86-2200-e-032-010-01.BOM	US English, LA Spanish, Canadian French, Brazilian Portuguese, UK English, French, Swiss French, Belgian French
NS-x86-2200-e-032-010-02.BOM	US English, German, French, Swedish, Finnish, Danish, Norwegian, Dutch, UK English, Swiss German, Belgian Dutch, Canadian French, Swiss French, Belgian French
NS-x86-2200-e-032-010-03.BOM	US English, Swiss German, Spanish, Belgian French, Swiss French, Swiss Italian, Italian, Belgian Dutch, Portuguese, UK English, German, Dutch, French, Canadian French

The following are available regardless of the flash file that you choose:

- Basic keyboard language support
- Messages that are translated into US English

Appendix F. Monitor specifications

A basic video graphics adapter (VGA) class monitor that meets the VESA standards of refresh rate and resolution can function with the thin client. The thin client supports VESA Display Power Management Signaling (DPMS) and VESA Display Data Channel (DDC2B). A monitor that is attached to the thin client does not require either standard. You configure the resolution in each case at the client operating system (OS) level.

Your monitor may not support all resolutions and refresh rates.

Table 13. Monitor support

High color (16 bit) and 256 color (8 bit)	
Resolution (pixels)	Refresh Rate (Hz)
640x480	60, 75, 85
800x600	60, 75, 85
1024x768	43, 60, 75, 85
1280x1024	60, 75, 85
1600x1200	48, 60, 75, 85

Appendix G. Connector pin information

The following tables define the connector pins that are used with the N2800e thin client.

Table 14. Monitor Connector

Pin	Signal	Signal Direction
1	Red Video	Out
2	Green Video	Out
3	Blue Video	Out
4	Monitor Detect 2	In
5	Ground	---
6	Red Video Ground	---
7	Green Video Ground	---
8	Blue Video Ground	---
9	Not connected	---
10	Ground	---
11	Monitor Detect 0	In
12	Monitor Detect 1 / DDCSDA	In / Out
13	Horizontal Sync	Out
14	Vertical Sync	Out
15	Monitor Detect 3 / DDCSCL	In / Out
Connector shell	Protective Ground	---

Table 15. Keyboard and Mouse Connectors

Pin	Signal
1	Data
2	Reserved
3	Ground
4	+5V dc
5	Clock
6	Reserved

Table 16. Parallel Connector

Pin	Signal	Signal Direction
1	Strobe	In
2	Data 0	In
3	Data 1	In
4	Data 2	In
5	Data 3	In
6	Data 4	In
7	Data 5	In
8	Data 6	In
9	Data 7	In
10	ACKNLG	Out
11	BUSY	Out
12	PE	Out
13	SELECT	Out
14	AUTOFEEDXT	In
15	ERROR	Out

Table 16. Parallel Connector (continued)

Pin	Signal	Signal Direction
16	INIT	In
17	SELECTIN	In
18 - 25	Ground	- - -

Table 17. RJ-45 Twisted Pair Connector

Pin	Name	Function
1	TPOP	Transmit +
2	TPON	Transmit -
3	TPIP	Receive +
4/5	Not used	- - -
6	TPIN	Receive -
7/8	Not used	- - -

Table 18. USB connector

Pin #	Direction	Description
1	Power	Power (5V) for USB0
2	Bidir	Data positive for USB0
3	Bidir	Data negative for USB0
4	Power	Ground for USB0
5	Power	Power (5V) for USB1
6	Bidir	Data positive for USB1
7	Bidir	Data negative for USB1
8	Power	Ground for USB1

Table 19. Power supply connector

Pin #	Voltage+5V dc
1	+5V dc
2	+5V dc
3	+3.3V dc
4	+3.3V dc
5	+3.3V dc
6	+12V dc
7	Power Good
8	Ground
9	Ground
10	Ground
11	Ground
12	Ground
13	Ground
14	-12V dc

Notices

This information has been developed for products and services that are offered in the U.S.A. IBM may not offer the products, services, or features that are discussed in this document in other countries. Consult your local IBM representative for information on the products and services currently available in your area. Any reference to an IBM product, program, or service is not intended to state or imply that only that IBM product, program, or service may be used. Any functionally equivalent product, program, or service that does not infringe any IBM intellectual property right may be used instead. However, it is the user's responsibility to evaluate and verify the operation of any non-IBM product, program, or service.

IBM may have patents or pending patent applications that cover subject matter that is described in this document. The furnishing of this document does not give you any license to these patents. You can send license inquiries, in writing, to:

IBM Director of Licensing
IBM Corporation
North Castle Drive
Armonk, NY 10504-1785
U.S.A.

For license inquiries regarding double-byte character set (DBCS) information, contact the IBM Intellectual Property Department in your country or send inquiries, in writing:

IBM World Trade Asia Corporation
Licensing
2-31 Roppongi 3-chome, Minato-ku
Tokyo 106, Japan

The following paragraph does not apply to the United Kingdom or any other country where such provisions are inconsistent with local law:

INTERNATIONAL BUSINESS MACHINES CORPORATION PROVIDES THIS PUBLICATION "AS IS" WITHOUT WARRANTY OF ANY KIND, EITHER EXPRESS OR IMPLIED, INCLUDING, BUT NOT LIMITED TO, THE IMPLIED WARRANTIES OF NON-INFRINGEMENT, MERCHANTABILITY OR FITNESS FOR A PARTICULAR PURPOSE. Some states do not allow disclaimer of express or implied warranties in certain transactions; therefore, this statement may not apply to you.

This information could include technical inaccuracies or typographical errors. Changes are periodically made to the information herein; these changes will be incorporated in new editions of the publication. IBM may make improvements and changes in both the products and the programs described in this publication at any time without notice.

References in this information to non-IBM Web sites are provided for convenience only and do not in any manner serve as an endorsement of those Web sites. The materials at those Web sites are not part of the materials for this IBM product, and use of those Web sites is at your own risk.

Information concerning non-IBM products was obtained from the suppliers of those products, their published announcements, or other publicly available sources.

IBM has not tested those products and cannot confirm the accuracy of performance, compatibility, or any other claims related to non-IBM products. Questions on the capabilities of non-IBM products should be addressed to the suppliers of those products.

All statements regarding IBM's future direction or intent are subject to change or withdrawal without notice, and represent goals and objectives only.

If you are viewing this information softcopy, the photographs and color illustrations may not appear.

The drawings and specifications contained herein shall not be reproduced in whole or in part without the written permission of IBM.

IBM has prepared this publication for use by customer personnel for operating and planning for the specific machines indicated. IBM makes no representations that it is suitable for any other purpose.

As an Energy Star Partner, IBM has determined that the Type 8364 thin client meets the Energy Star Program guidelines for energy efficiency.



Environmental Design

The environmental efforts that have gone into the design of this product signify IBM's commitment to improving the quality of its products and processes. Some of these accomplishments include the following:

- Elimination of the use of Class I ozone-depleting chemicals in the manufacturing process
- Reduction in manufacturing wastes
- Increased product energy efficiency

Normal power consumption for the thin client, while running applications, is approximately 18 Watts. For more information, contact an IBM account representative.

Product Recycling and Disposal

You can recycle components, such as structural parts and circuit cards, where recycling facilities exist. IBM does not currently collect and recycle used IBM products from customers in the United States other than those products that are involved in trade-in programs. Companies are available to disassemble, reuse, recycle, or dispose of electronic products. Contact an IBM account representative for more information.

This IBM thin client contains circuit boards with lead solder. Before you dispose of this unit, remove the circuit boards, and discard them according to local regulations or recycle them where facilities exist.

Trademarks

The following terms are trademarks of International Business Machines Corporation in the United States, or other countries, or both:

AS/400
IBM
NetVista
Network Station
S/390
Wake on LAN

Java™, and all Java-based trademarks, and logos are trademarks, or registered trademarks of Sun Microsystems, Inc. in the United States, other countries, or both.

Microsoft®, Windows, Windows NT, and the Windows logo are trademarks of Microsoft Corporation in the United States, other countries, or both.

Electronic Emission Notices

The following Statement applies to this IBM product. The statement for other IBM products intended for use with this product will appear in their accompanying manuals.

Federal Communications Commission (FCC) Statement

Note: This equipment has been tested and found to comply with the limits for a class B digital devices, pursuant to Part 15 of the FCC Rules. These limits are designed to provide reasonable protection against harmful interference in a residential installation. This equipment generates, uses, and can radiate radio frequency energy and, if not installed and used in accordance with the instructions, may cause harmful interference to radio communications. However, there is no guarantee that interference will not occur in a particular installation. If this equipment does cause harmful interference to radio or television reception, which can be determined by turning the equipment off and on, the user is encouraged to try to correct the interference by one or more of the following measures:

- Reorient or relocate the receiving antenna.
- Increase the separation between the equipment and receiver.
- Connect the equipment into an outlet on a circuit different from that to which the receiver is connected.
- Consult an IBM authorized dealer or service representative for help.

Properly shielded and grounded cables and connectors must be used in order to meet FCC emission limits. Proper cables and connectors are available from IBM authorized dealers. IBM is not responsible for any radio or television interference caused by using other than recommended cables or connectors or by unauthorized changes or modifications to this equipment. Unauthorized changes or modifications could void the user's authority to operate the equipment.

This device complies with Part 15 of the FCC Rules. Operation is subject to the following two conditions: (1) this device may not cause harmful interferences, and (2) this device must accept any interferences received, including interference that may cause undesired operation.

Responsible Party:

International Business Machines Corporation
New Orchard Road
Armonk, NY 10504

Telephone: 1-919-543-2193

Industry Canada Compliance Statement

This Class B digital apparatus meets the requirements of the Canadian Interference-Causing Equipment Regulations.

Avis de conformité à la réglementation d'Industrie Canada

Cet appareil numérique de la classe B respecte toutes les exigences du Règlement sur le matériel brouilleur du Canada.

European Community Compliance Statement

This product is in conformity with the protection requirements of EC Council Directive 89/336/EEC on the approximation of the laws of the Member States relating to electromagnetic compatibility. IBM cannot accept responsibility for any failure to satisfy the protection requirements resulting from a non-recommended modification of the product, including the fitting of non-IBM option cards.

This product has been tested and found to comply with the limits for Class B Information Technology Equipment according to CISPR 22 / European Standard EN 55022. The limits for Class B equipment were derived for typical residential environments to provide reasonable protection against interference with licensed communication devices.

Properly shielded and grounded cables and connectors (IBM part number 75G5958 or its equivalent) must be used in order to reduce the potential for causing interference to radio and TV communications and to other electrical or electronic equipment. Such cables and connectors are available from IBM authorized dealers. IBM cannot accept responsibility for an interference caused by using other than recommended cables and connectors.

Glossary of abbreviations

A

AC. Alternating Current

ARP. Address Resolution Protocol

B

BOM. Bill of Material

BOOTP. Bootstrap Protocol

C

CD. Compact Disc

CRU. Customer-Replaceable Unit

Cxx. Thin Client Express model

D

DBCS. Double Byte Character Set

d.d.d.d. IP address format

DC. Direct Current

DCE. Data Communications Equipment

DDC. Display Data Channel

DDC2B. Display Data Channel (version 2B)

DHCP. Dynamic Host Configuration Protocol

DIMM. Dual In-line Memory Module

DMA. Direct Memory Access

DNS. Domain Name Server

DPMS. Display Power Management Signaling

DTE. Data Terminal Equipment

F

FAX. Facsimile

FCC. Federal Communications Commission

FTP. File Transfer Protocol

FRU. Field Replaceable Unit

H

HTTP. Hypertext Transfer Protocol

Hz. Hertz or cycles per second

I

IBM. International Business Machines

ICA. Independent Computing Architecture

ICMP. Internet Control Message Protocol

ISO. International Organization for Standardization

ID. Identification

IEEE. Institute of Electrical and Electronics Engineers

IP. Internet Protocol

IRQ. Interrupt Request

L

LA. Latin American

LAN. Local Area Network

LED. Light Emitting Diode

LLC. Logical Link Control

M

MAC. Medium Access Control

Mb. Megabit

MB. Megabyte

MHz. Megahertz

MTU. Maximum Transmission Unit

N

N2800e. IBM NetVista Thin Client Express

NFS. Network File Server

NS. Network Station

NSB. Network Station Boot

NSBXXXXX. Network Station Boot message with identification number (XXXXX)

NSM. Network Station Manager

NVRAM. Nonvolatile Random Access Memory (also referred to as local settings)

O

OS. Operating System

P

PC. Personal Computer

POST. Power On Self Test

PPP. Point-to-Point Protocol

R

RAM. Random Access Memory

RAP. Remote Authentication Protocol

RIF. Routing Information Field

RFS. Remote File System

S

SDRAM. Synchronous Dynamic Random Access Memory

SNMP. Simple Network Management Protocol

T

TCM. Thin Client Manager

TCP/IP. Transmission Control Protocol / Internet Protocol

TFTP. Trivial File Transfer Protocol

TSE. Windows NT Server 4.0, Terminal Server Edition

U

UDP. User Datagram Protocol

UK. United Kingdom

URL. Uniform Resource Locator

US. United States

USB. Universal Serial Bus

UTP. Unshielded Twisted Pair

V

V. Volts

VESA. Video Electronics Standards Association

VGA. Video Graphics Array

VM. Virtual Machine

VT. Virtual Terminal

W

WAN. Wide Area Network

WBT. Windows-Based Terminal

WOL. Wake On LAN

WWW. World Wide Web

Index

A

- access
 - configuring initial modem settings for PPP dialer 22
 - prerequisites for using PPP 21

B

- BOM file, choosing a 55
- boot block image 53
 - recovering 53

C

- CD
 - installing the utilities from the NetVista Thin Client Utilities CD 16
- CompactFlash card, replacing the N2800e Thin Client Express 41
- configuration
 - preparing the workstation for PPP dialer 21
- Configuration Tool 12
 - accessing 13
 - using the configuration tool to perform a software update on a workstation 25
- configuring
 - N2800e 11
 - using the Configuration Tool 12
 - using the Setup Utility 11
- configuring a workstation for PPP dialer 21
- configuring initial modem settings for PPP dialer access 22
- connector pin information 59
- connector pins 3
- connectors
 - hardware 3

D

- dial access
 - prerequisites for using PPP 21
- dialer
 - configuring a workstation for PPP 21
 - configuring initial modem settings for PPP access 22
 - maintaining and reconfiguring PPP dialer parameters 23
 - PPP 21
 - preparing a workstation for PPP 21
 - starting the PPP 23
 - troubleshooting PPP problems 24
 - using the PPP dialer to access flash images 24
- dialer window, learning about the 23

- disabling peer flash recovery on a workstation 29
- downloading the utilities from the NetVista Thin Client website 16

F

- flash
 - choosing a flash file 55
- flash file, choosing a 55
- flash image
 - altering the flash image of a workstation 25
 - recovering 26
 - using peer recovery to recover the flash image 27
 - using TCM to recover the flash image 30
 - using the Setup Utility to recover the flash image 29
- flash images
 - using the PPP dialer to access 24
- flash recovery 26
 - disabling peer flash recovery 29
 - enabling peer flash recovery 27

H

- hardware
 - boot block image 53
 - communication cables 4
 - connectors 3
 - detailed information 3
 - display resolutions 4
 - ethernet 4
 - hardware procedures 4
 - monitor specifications 4
 - ordering replacement parts 42
 - parts 41
 - ports 3
 - power consumption 4
 - power reduction 4
 - problem indications 31
 - refresh frequency 4
 - replacing parts 41
 - resolving problems 31
 - returning parts 44
 - setting up 7
 - standard 3
 - type and model 3, 4
 - upgrading memory 4
 - USB devices 4
 - verifying problems 31
- hardware features
 - memory upgrade 4
 - USB devices 4
- hardware parts 41, 42, 44
- hardware problems
 - audio beep sequences 34
 - error codes and text messages 36
 - LED indications 35

- hardware problems (*continued*)
 - visible hardware failure 32

I

- image
 - altering the flash image of a workstation 25
 - using peer recovery to recover the flash 27
- images
 - using the PPP dialer to access flash images 24
- information
 - connector pin 59
- initial modem settings for PPP dialer access, configuring 22
- installing
 - management utilities 15
 - utilities from the NetVista Thin Client Utilities CD 16
- installing NetVista Thin Client management utilities from website 16
- installing the power supply 49
- introduction 1

L

- location
 - selecting the voltage for your 51

M

- maintaining and reconfiguring PPP dialer parameters 23
- managing your Thin Client Express remotely 19
- modem settings for PPP dialer access 22
- monitor
 - display resolutions 4
 - refresh frequency 4
 - specifications 4
- monitor specifications 57

N

- N2800e
 - boot block image 53
 - configuring 11
 - hardware 3
 - hardware parts 41, 42, 44
 - hardware problems 31
 - installing management utilities 15
 - ordering replacement parts 42
 - remote management 19
 - replacing hardware parts 41
 - returning parts 44
 - setting up 7
 - startup sequence 9

N2800e (*continued*)
 understanding 1
NC dialer window, learning about
 the 23
NetVista Thin Client
 website 16
network cables 4

O

Operations Utility
 installing 15
 using TCM to perform a software
 update on a workstation 26
 using TCM to recover the flash image
 of a workstation 30
ordering replacement parts 42

P

parameters
 maintaining and reconfiguring PPP
 dialer parameters 23
peer-booted workstation
 recovering the image 28
peer flash recovery 27
 disabling 29
 enabling 27
pin information
 connector 59
power consumption 4
power on 9
 startup sequence 9
power supply
 installing the 49
 removing the 48
 replacing the 48
PPP
 prerequisites for using 21
PPP dial access, prerequisites for
 using 21
PPP dialer
 configuring a workstation for 21
 configuring initial modem settings
 for 22
 for Thin Client Express
 workstations 21
 preparing a workstation for 21
 starting the 23
 troubleshooting 24
 using to access flash images 24
PPP dialer parameters
 maintaining and reconfiguring 23
prerequisites
 for using PPP dial access 21
problems
 troubleshooting PPP dialer 24

R

reconfiguring PPP dialer parameters 23
recovering the flash image of a
 workstation 26
recovery
 disabling peer flash recovery 29
 enabling peer flash recovery 27
 peer flash 27

recovery (*continued*)
 recovering the flash image 28
 using TCM to recover the flash image
 of a workstation 30
 using the Setup Utility to recover the
 flash image of a workstation 29
remote
 Managing your Thin Client Express
 remotely 19
removing the power supply 48
replacing hardware parts 41
replacing the N2800e Thin Client Express
 CompactFlash card 41
replacing the power supply 48
resolving problems 31
returning hardware parts 44

S

selecting the voltage for your
 location 51
Service Utility 15
settings
 configuring initial modem for PPP
 dialer access 22
Setup Utility 11
 example menu 11
 navigation 12
 recovering the flash image of a
 workstation 29
software update
 on a workstation 25
 using TCM to perform a software
 update 26
 using the Configuration Tool to
 perform a software update 25
startup sequence 9

T

Thin Client Express
 boot block image 53
 configuring 11
 hardware 3
 hardware parts 41, 42, 44
 hardware problems 31
 installing management utilities 15
 ordering replacement parts 42
 PPP dialer for 21
 remote management 19
 replacing hardware parts 41
 returning parts 44
 setting up 7
 startup sequence 9
 understanding 1
Thin Client Manager Operations Utility
 using TCM to perform a software
 update on a workstation 26
 using TCM to recover the flash image
 of a workstation 30
troubleshooting 31
 PPP dialer problems 24

U

update
 software update of a workstation 25

update (*continued*)
 using TCM to perform a software
 update 26
 using the Configuration Tool to
 perform a software update 25
utilities
 installing from the NetVista Thin
 Client Utilities CD 16
utility
 operations 15
 service 15
 setup 11

V

verifying problems 31
voltage
 selecting the voltage for your
 location 51

W

website
 NetVista Thin Client 16
website for NetVista Thin Client
 Utilities 16
Windows 2000 Advanced Server 15
Windows 2000 Professional 15
Windows 2000 Server 15
Windows NT Server 4.0 15
Windows NT Server 4.0 Terminal Server
 Edition (TSE) 15
Windows NT Workstation 4.0 15
workstation
 altering the flash image 25
 configuring for PPP dialer 21
 disabling peer flash recovery 29
 enabling peer flash recovery 27
 peer flash recovery 27
 performing a software update 25
 PPP dialer for Thin Client Express 21
 preparing for PPP configuration 21
 recovering the flash image 26
 recovering the image on a peer-booted
 workstation 28
 remote management 19
 using TCM to perform a software
 update 26
 using TCM to recover the flash
 image 30
 using the Configuration Tool to
 perform a software update 25
 using the Setup Utility to recover the
 flash image 29

Readers' Comments — We'd Like to Hear from You

NetVista™

N2800e Thin Client Express

Reference

September 2000

To view or print the latest update, go to <http://www.ibm.com/nc/pubs>

Publication No. SA23-2808-00

Overall, how satisfied are you with the information in this book?

	Very Satisfied	Satisfied	Neutral	Dissatisfied	Very Dissatisfied
Overall satisfaction	<input type="checkbox"/>	<input type="checkbox"/>	<input type="checkbox"/>	<input type="checkbox"/>	<input type="checkbox"/>

How satisfied are you that the information in this book is:

	Very Satisfied	Satisfied	Neutral	Dissatisfied	Very Dissatisfied
Accurate	<input type="checkbox"/>	<input type="checkbox"/>	<input type="checkbox"/>	<input type="checkbox"/>	<input type="checkbox"/>
Complete	<input type="checkbox"/>	<input type="checkbox"/>	<input type="checkbox"/>	<input type="checkbox"/>	<input type="checkbox"/>
Easy to find	<input type="checkbox"/>	<input type="checkbox"/>	<input type="checkbox"/>	<input type="checkbox"/>	<input type="checkbox"/>
Easy to understand	<input type="checkbox"/>	<input type="checkbox"/>	<input type="checkbox"/>	<input type="checkbox"/>	<input type="checkbox"/>
Well organized	<input type="checkbox"/>	<input type="checkbox"/>	<input type="checkbox"/>	<input type="checkbox"/>	<input type="checkbox"/>
Applicable to your tasks	<input type="checkbox"/>	<input type="checkbox"/>	<input type="checkbox"/>	<input type="checkbox"/>	<input type="checkbox"/>

Please tell us how we can improve this book:

Thank you for your responses. May we contact you? Yes No

When you send comments to IBM, you grant IBM a nonexclusive right to use or distribute your comments in any way it believes appropriate without incurring any obligation to you.

Name

Address

Company or Organization

Phone No.

Readers' Comments — We'd Like to Hear from You
SA23-2808-00



Cut or Fold
Along Line

Fold and Tape

Please do not staple

Fold and Tape

PLACE
POSTAGE
STAMP
HERE

IBM CORPORATION
ATTN DEPT 542 IDCLERK
3605 Highway 52 N
ROCHESTER MN
55901-7829

Fold and Tape

Please do not staple

Fold and Tape

SA23-2808-00

Cut or Fold
Along Line



SA23-2808-00

