



Communication Interface Module

Cat. No. 1784-KT2/C

Installation Data

About the 1784-KT2/C Communication Interface Module

The 1784-KT2/C Communication Interface Module allows you to use an IBM PS/2 compatible MicroChannel computer to communicate with:

- Allen-Bradley PLC-2 and PLC-3 family programmable controllers
- all Data Highway Plus family programmable controllers

The 1784-KT2/C conducts the data communication, management, and local Data Highway Plus diagnostics. The interface to the personal computer is through board-resident shared memory that passes preformatted Data Highway Plus packets. Upon powering up the computer and downloading module code, diagnostics are run automatically to verify the 1784-KT2/C's operation. Allen-Bradley 6001-F1E2 software manages the transmission and reception of data through board-resident shared memory.

Features

The 1784-KT2/C Communication Interface Module is an IBM PS/2® MicroChannel card that you can insert into any 8- or 16-bit IBM PS/2 expansion slot. In addition, the 1784-KT2/C:

- makes your PS/2 computer an active node on a Data Highway Plus network
- provides single cable connection to a PLC-2, PLC-3, or PLC-5 family programmable controller
- operates with 6200 programming software
- is address selectable; you can use it with other option boards installed in your PS/2 computer
- when combined with Allen-Bradley 6001-F1E2 software, allows you to create your own custom interface to a Data Highway Plus network

Compatibility

The 1784-KT2/C has been verified for operation with the following computers:

- Allen-Bradley 6123, 6124
- IBM PS/2 7541, 7561, 8550, 8555, 8560, 8570, 8580

We will refer to the 1784-KT2/C Communication Interface Module as simply the 1784-KT2 throughout this document.

What this Document Contains

The remainder of this document contains information on the following topics:

For information on:	Refer to page:
Important User Information	2
Preparing the Reference Diskette for Configuration	4
Installing the 1784-KT2	7
Configuring the 1784-KT2	8
Connecting the 1784-KT2	10
The 1784-KT2 Diagnostic Program	14
Building Loopback Connectors	29
Specifications	31

Important User Information

Because of the variety of uses for products described in this publication, those responsible for the application and use of this control equipment must satisfy themselves that all necessary steps have been taken to assure that each application and use meets all performance and safety requirements, including any applicable laws, regulations, codes and standards.

The illustrations, charts, sample programs and layout examples shown in this guide are intended solely for purposes of example. Since there are many variables and requirements associated with any particular installation, Allen-Bradley does not assume responsibility or liability (to include intellectual property liability) for actual use based upon the examples shown in this publication.

Allen-Bradley publication SGI-1.1 “Safety Guidelines for the Application, Installation and Maintenance of Solid State Control” (available from your local Allen-Bradley office) describes some important differences between solid-state equipment and electromechanical devices which should be taken into consideration when applying products such as those described in this publication.

Reproduction of the contents of this copyrighted publication, in whole or in part, without written permission of Allen-Bradley Company, Inc. is prohibited.



WARNING: With any complex communication system you need to identify potential application-related communication problems and make provisions in the system design to prevent hazardous or undesired consequences if a problem occurs. These problems include, but are not necessarily limited to, the possibility of:

- unexpected loss of communication
- erroneous or incomplete data being supplied to the network and passed on to your application



WARNING: The following provides information for Allen-Bradley Industrial Computer and Communication Group (ICCG) products that have been verified to meet the Electromagnetic Interference (EMI) requirements of the Federal Communication Commission (FCC) and the Canadian Department of Communications for use in a commercial environment:

This device complies with Part 15 of the FCC rules. Operation is subject to the following two conditions: (1) this device may not cause harmful interference, and (2) this device must accept any interference received, including interference that may cause undesired operation.



WARNING: This digital apparatus does not exceed the Class A limits for radio noise emissions from digital apparatus set out in the Radio Interference Regulations of the Canadian Department of Communications.

Le présent appareil numérique n'émet pas de bruits radioélectriques dépassant les limites applicables aux appareils numériques de la class A prescrites dans le Règlement sur le brouillage radioélectrique édicté par le ministre des Communications du Canada.

Preparing the Reference Diskette for Configuration

Preparing the IBM PS/2 Reference diskette for 1784-KT2 configuration capability, involves:

- creating backup diskettes
- copying the 1784-KT2 Adapter Description file
- creating a backup of the PS/2 configuration

The following sections provide information on these procedures.

Creating Backup Diskettes

Before installing or configuring your 1784-KT2 you need to make backup copies of the following:

- 1784-KT2 Options and Diagnostics diskette
- Most recent version of the IBM PS/2 Reference diskette

Follow IBM instructions for completing this process.

Important: After you have created the backup copies, store the original diskettes. **All procedures from this point on will be performed using the backup diskettes.**

Copying the 1784-KT2 Adapter Description File

This section explains how to copy the 1784-KT2 Adapter Description file (60C6.ADF) from the 1784-KT2 Options and Diagnostics diskette to the IBM PS/2 Reference diskette. You cannot configure the 1784-KT2 until the Adapter Description file is added to the IBM PS/2 Reference diskette.

To copy the Adapter Description file, follow these steps:

1. Insert the IBM PS/2 Reference diskette into drive A of your computer.

2. Press the [Control], [Alt] and [Del] keys at the same time.
3. When you receive the following message, press [ENTER].
Press [ENTER) to continue.

4. The main menu appears:

MAIN MENU

1. **Learn about the computer**
2. **Backup the Reference Diskette**
3. **Set configuration**
4. **Set features**
5. **Copy an option diskette**
6. **Move the computer**
7. **Test the computer**

Use ↑ or ↓ to select. Press Enter.

Escape=Quit F1=Help

Move the cursor down to the **Copy an Option Diskette** option and press [ENTER].

5. When the following message appears, insert the 1784-KT2 Options and Diagnostic diskette into drive A and press [ENTER]:

Remove your backup copy of the Reference diskette and insert the options diskette into drive A.

6. Follow the instructions on your screen.

This process copies only the 1784-KT2 Adapter Description file to the IBM PS/2 Reference diskette. When this copy procedure is complete, store both diskettes.

Creating a Backup of the PS/2 Configuration

Important: You need to copy the Adapter Description file to the IBM PS/2 Reference diskette before you perform this procedure. If you have not yet done so, turn to the previous section for instructions.

To create a backup of the PS/2 computer's configuration, follow these steps:

1. Insert the IBM PS/2 Reference diskette into drive A.

2. Cycle the power switch. When the following message appears, press [ENTER]:

Press [ENTER) to continue.

3. When the main menu appears move the cursor down to the **Set Configuration** option and press [ENTER].

MAIN MENU

1. **Learn about the computer**
2. **Backup the Reference Diskette**
3. **Set configuration**
4. **Set features**
5. **Copy an option diskette**
6. **Move the computer**
7. **Test the computer**

Use ↑ or ↓ to select. Press Enter.

Escape=Quit F1=Help

4. When the Set Configuration menu appears move the cursor down to the **Backup Configuration** option and press [ENTER].

Set Configuration

1. **View configuration**
2. **Change configuration**
3. **Backup configuration**
4. **Restore configuration**
5. **Run automatic configuration**

Press a number to select

Esc=Quit F1=Help

This creates a backup of your PS/2 computer's current configuration.

5. When the procedure is complete, press [ENTER] to return to the Set Configuration menu.
6. Press [ESC] to quit.
7. Remove the IBM PS/2 Reference diskette from drive A and re-start the PS/2 computer.

Installing the 1784-KT2

This section explains how to install the 1784-KT2 into an Allen-Bradley 6123 or 6124, or an IBM PS/2 computer. When installing the module into a 6123 or 6124, refer to the 6123/6124 User's Manual (publication 6123-2.1) for additional considerations.

Important: Read the IBM PS/2 Model Quick Reference guide before you install the 1784-KT2. Pay close attention to the section entitled "Installing Options" for additional considerations when installing the 1784-KT2.



CAUTION: The 1784-KT2 uses CMOS Technology, which is highly sensitive to electrostatic discharge (ESD). ESD may be present whenever you are handling the 1784-KT2. Handling the 1784-KT2 without any ESD protection can cause internal circuit damage that may not be apparent during installation or initial use. A grounding wrist strap has been shipped with the 1784-KT2 to be worn during the installation procedure. Instructions for use of the strap are found on the back of its package.

The following is a list of precautions to guard against ESD damage:

- Before handling the module, be sure to wear the provided static strap and touch a grounded object to discharge any built-up static charge.
- Avoid touching the backplane connector or interface connector pins located on the 1784-KT2.
- If the module is not in use, store the 1784-KT2 in the static bag that the module was shipped in.

To install the 1784-KT2, follow these steps:

1. Disconnect the ac power to the computer.
2. Remove the computer's system-unit cover (according to the manufacturer's instructions).
3. Select a vacant 8- or 16-bit expansion slot.
Important: The 1784-KT2 will function in an 8- or a 16-bit expansion slot only.
4. Remove the rear bracket slot's expansion cover by loosening the screw on the back of the computer.
5. Insert the 1784-KT2 into the edge connector and tighten the expansion slot screw.
6. Replace the system-unit cover.
7. Connect the ac power to the computer.

You are now ready to configure your 1784-KT2. Refer to the next section.

Configuring the 1784-KT2

Important: You need to prepare the PS/2 Reference diskette for 1784-KT2 configuration capability. If you have not yet done so, refer to the section earlier in this document.

To configure the 1784-KT2, follow these steps:

1. Insert the IBM PS/2 Reference diskette into drive A.
2. Turn on the computer.
3. During the boot process, the computer beeps twice and error code 165 appears on the screen. This indicates an adapter configuration change. When the following message appears, press [ENTER]

Press Enter to continue
4. When you receive the following message, type n and press [ENTER].

Automatically configure the system? (Y/N)
5. When the main menu appears, move the cursor down to the **Set Configuration** option and press [ENTER].
6. When the Set Configuration menu appears, move the cursor down to the **Change Configuration** option and press [ENTER]. A configuration table with the following type of information appears (variation is probable):

Change Configuration

```
Total System Memory
  Installed Memory . . 2048KB (2.0MB)
  Useable Memory . . 2048KB (2.0MB)

Built-In Features
  Installed Memory . . 2048KB (2.0MB)
  Diskette Drive A Type . . . . . 1.44MB [3.5"]
  Diskette Drive B Type . . . . . [Not Installed]
  Math Coprocessor . . . . . [Not Installed]
  Serial Port . . . . . [Serial_1]
  Parallel Port . . . . . [Parallel_1]

Slot 1-Allen-Bradley Company 1784-KT2
  Memory Address . . [0C0000h-0C3FFFh]
  Interrupt Level . . . [IRQ9]
  Auxiliary Communication
  Port . . . . . [PLC-2/-3 Direct Connect]

Esc=Quit  F5=Previous  F10=Save  Home  Page up
F1=Help  F6=Next  End  Page Down
```

7. Select a memory address by moving the cursor down to the 1784-KT2 **Memory Address** option.



CAUTION: Configuring two adapter cards at the same address may damage your cards and your PS/2 computer.

Use [F5] and [F6] to scroll back and forth through the addresses. Display your selection on the screen. Make sure you select an address that is not being used by another adapter card in your PS/2 computer. If you select an address currently in use, an asterisk will appear next it.

The 1784-KT2 supports the following memory addresses (in hexadecimal):

```
0C0000 – 0C3FFF
0C4000 – 0C7FFF
0C8000 – 0CBFFF
0CC000 – 0CFFFF
0D0000 – 0D3FFF
0D4000 – 0D7FFF
0D8000 – 0DBFFF
0DC000 – 0DFFFF
```

8. Set the interrupt level by moving the cursor down to the **Interrupt Level option**.

Use [F5] and [F6] to scroll back and forth through the interrupts. Display your selection on the screen. Make sure you select an interrupt that is not being used by another adapter card in your PS/2 computer.

The 1784-KT2 supports the following interrupts:

IRQ9
IRQ10
IRQ11
IRQ12

If you are using a PLC-2 or PLC-3, continue with **Step 9**.
If you are not using a PLC-2 or PLC-3, continue with **Step 10**.

9. Use [F5] and [F6] to set the auxiliary communication port to **PLC-2/3 Direct Connect**.
10. Press [F10] to save the memory, interrupt, and auxiliary communication port options.
11. You are asked if you want to continue. Press [ENTER].
12. Press [ESC] to return to the Set Configuration menu.
13. Press [ESC] again. A message indicating a configuration change has been made appears on your screen. Remove the IBM PS/2 Reference diskette.
14. Press [ENTER] to restart the computer.

Connecting the 1784-KT2

Important: Make sure you have the software that supports connecting the 1784-KT2 to your programmable controller. If you are not sure your software supports this connection, contact your local Allen-Bradley sales office

The following sections provide directions for connecting a 1784-KT2 to a PLC-2, PLC-3, or PLC-5. Refer to Table 1 for the catalog numbers of the cables you need to use and the corresponding PLCs.

Table 1
Required Cables for Connecting to a Programmable Controller

Use this cable:	When connecting to:
1784-CP2	PLC-2 Family Programmable Controllers
1784-CP3	PLC-3 Family Programmable Controllers
1784-CP	PLC-5 Family Programmable Controllers
1784-CP6	PLC-5/40 and PLC-5/60 Programmable Controllers (refer to publication 1784-2.26)
1784-CP7 Adapter with 1784-CP Cable	PLC-5/40 and PLC-5/60 Programmable Controllers (refer to publication 1784-2.29)

Connecting the 1784-KT2 to a PLC-2

To connect the 1784-KT2 to a PLC-2, follow these steps:



WARNING: To avoid personal injury, always disconnect the ac power before making the cable connection.

1. Plug the 62-pin connector end of the 1784-CP2 cable into the 1784-KT2 and secure with captive screws.

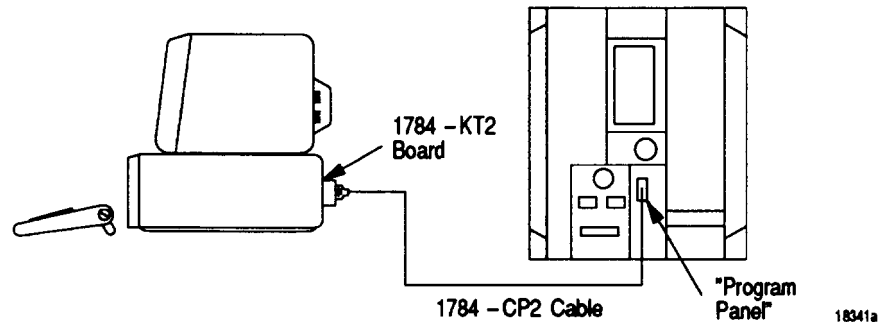

2. Connect the other end of the 1784-CP2 cable into the PROGRAM PANEL connector on the PLC-2.
3. Reinstall the ac power cord and turn on the computer.

Figure 1 shows cable pinouts for the 1784-CP2 cable.

Figure 1
Cable Pinouts for the 1784-CP2 Cable

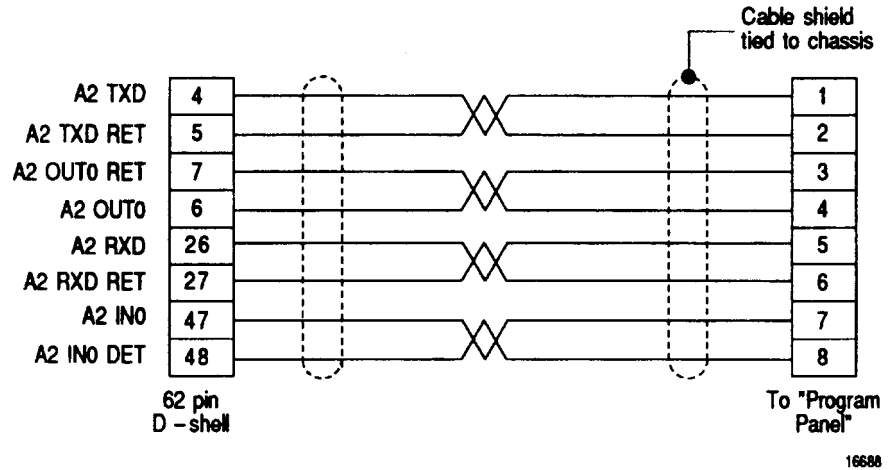

Connecting the 1784-KT2 to a PLC-3

To connect the 1784-KT2 to a PLC-3, follow these steps:



WARNING: To avoid personal injury, always disconnect the ac power before making the cable connection.

1. Plug the 62-pin connector end of the 1784-CP3 cable into the 1784-KT2 and secure with captive screws.

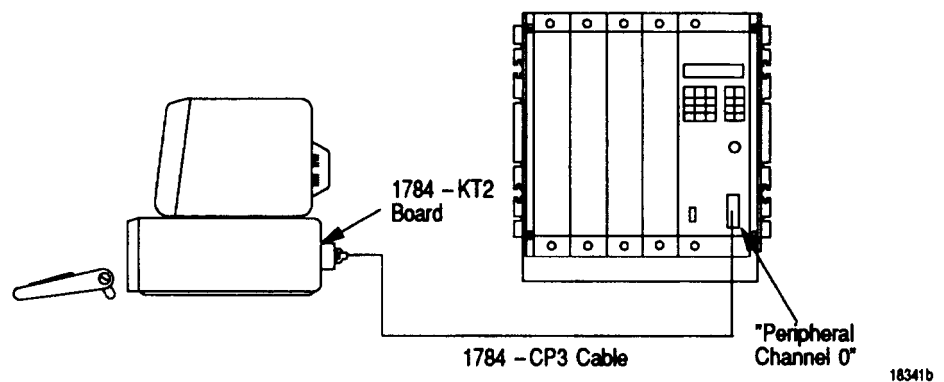

2. Connect the other end of the 1784-CP3 cable (labeled "Industrial Terminal End") into the PERIPHERAL CHANNEL 0 connector on the PLC-3.
3. Reinstall the ac power cord and turn on the computer.

Figure 2 shows cable pinouts for the 1784-CP3 cable.

Figure 2
Cable Pinouts for the 1784-CP3 Cable

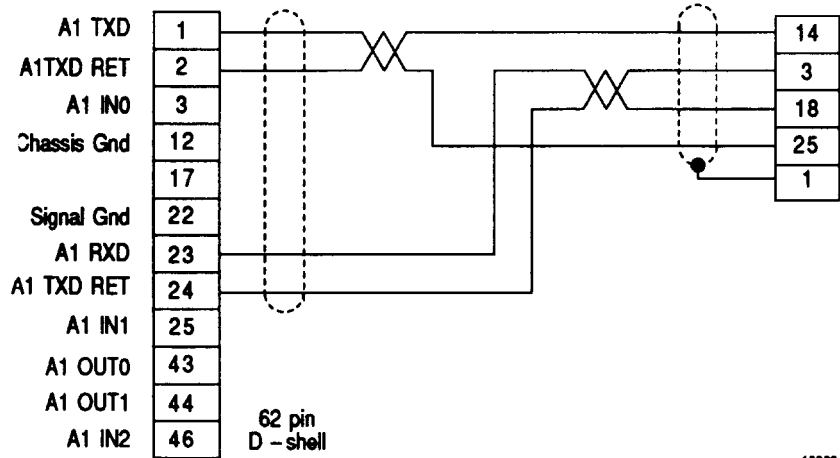

16689

Connecting the 1784-KT2 to a PLC-5

To connect the 1784-KT2 to a PLC-5, follow these steps:



WARNING: To avoid personal injury, always disconnect the ac power before making the cable connection.

1. Plug the 62-pin connector end of the 1784-CP cable into the 1784-KT2 and secure with captive screws.

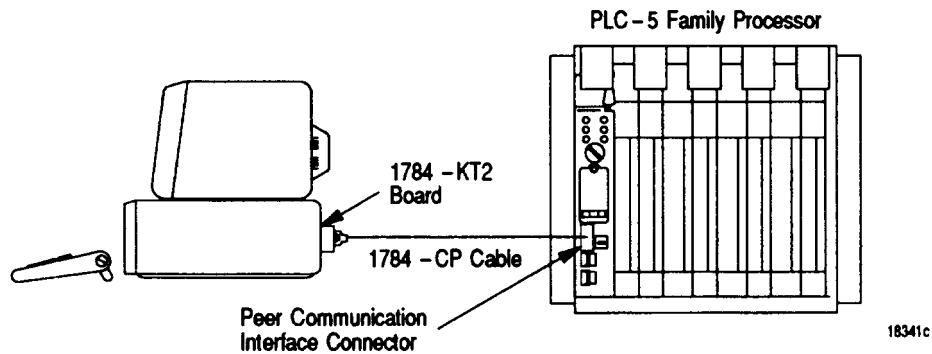

18341c

2. Connect the other end of the 1784-CP cable into the PEER COMM INTFC connector on the PLC-5.
3. Reinstall the ac power cord and turn on the computer.

Important: To allow communication between PLC-5s and other Data Highway Plus nodes, you must connect your PS/2 to a PLC-5 using a 1784-CP cable. The Data Highway Plus network is connected to the PLC-5.

Figure 3 shows cable pinouts for the 1784-CP cable.

Figure 3
Cable Pinouts for the 1784-CP Cable

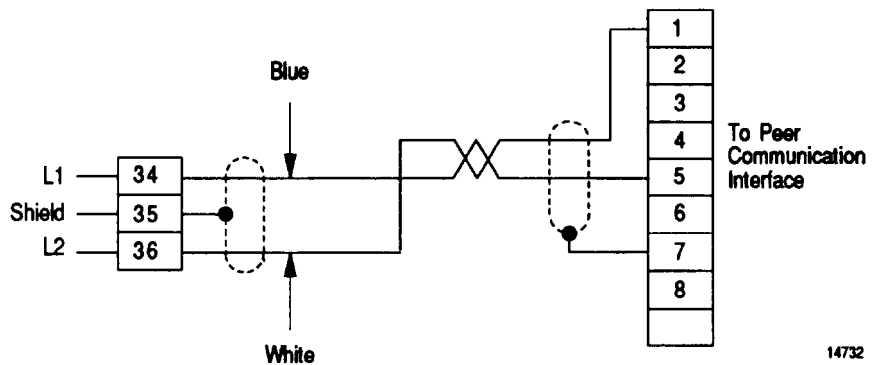

The 1784-KT2 Diagnostic Program

The 1784-KT2 Diagnostic Program allows you to execute a set of tests to help you make sure the 1784-KT2 is functioning properly. These tests check various operational characteristics, such as network and host communications, interrupts, and memory access. Test results are displayed on your screen and recorded in the diagnostic program output file.

Important: If the 1784-KT2 does not function properly under normal operation, follow these steps:

1. Check the configuration settings (refer to the section entitled “Configuring the 1784-KT2”). You may have configured the 1784-KT2 at an address already in use by another adapter module.
2. If the 1784-KT2 continues to function improperly, run the 1784-KT2 Diagnostic Program to determine if there are any hardware failures. If hardware failures are indicated, refer to the output file for resulting error messages. (Refer to the sections entitled “Output File” and “Error Messages” for additional information.)
3. If, after following steps 1 and 2, the 1784-KT2 continues to function improperly, contact your local Allen-Bradley sales office.

To properly execute the diagnostic program, you must have the following:

- an IBM PS/2 7541, 7561, 8550, 8555, 8560, 8570, or 8580 computer with the 1784-KT2 installed

OR

- an Allen-Bradley 6123 or 6124 computer with the 1784-KT2 installed
- DOS V3.3 or greater
- a PLC-2 or PLC-3 loopback connector (required for Off-Line Communications Diagnostics tests)

For information on how to build the loopback connector, refer to section entitled “Building Loopback Connectors”.

Diagnostic Program Files

Listed below are the diagnostic program files that you can find on the Options and Diagnostics diskette:

- KT2DIAG.EXE
- KT2DLG.TXT
- KT2DLG.TXT
- @60C6.ADF
- KT<DIR>

The following files are located in the KT sub-directory:

- KT2ST0.BIN
- KT2ST1.BIN
- KT2ST2.BIN
- KT2INT.BIN
- KT2PLC2.BIN
- KT2PLC3.BIN
- KT2DHP.BIN

Installing the Diagnostic Program onto a Hard Disk

Important: If you have not already done so, create a backup copy of the Options and Diagnostics diskette according to IBM instructions.

Important: You are not required to install the diagnostic program onto a hard disk. However, if you choose to install the program onto the hard disk, follow this procedure.

In the following example, the hard disk is referred to as C:.

To install the diagnostic program onto a hard disk, follow these steps:

1. Turn on the computer.

2. When the prompt appears, type the following to select the hard disk:

```
c: [ENTER]
```

3. When the prompt appears, type the following to select the top directory of the hard disk:

```
cd c:\ [ENTER]
```

4. When the prompt appears, type the following to create a directory called KT:

```
mkdir kt [ENTER]
```

5. When the prompt appears, type the following to create a directory called KT2DIAG:

```
mkdir kt2diag [ENTER]
```

6. When the prompt appears, insert the backup copy of the Options and Diagnostics diskette into drive A:.

7. Type the following to copy the Z80 diagnostic files to the KT directory:

```
copy a:\kt\*. * c:\kt [ENTER]
```

8. When the prompt appears, type the following to copy the diagnostic program files to the KT2 directory:

```
copy a:\*. * c:\kt2diag [ENTER]
```

The diagnostic program now resides in the C:\KT2DIAG directory, and the files the diagnostic program depends on now reside in the C:\KT directory.

Starting up the Diagnostic Program

Read the following checklist to help avoid damage to your network before starting up the diagnostic program:

- Make sure your network or PLC is **not** connected to a 1784-KT2 while the diagnostic program is running.
- Make sure other programs are **not** running at the same time the diagnostic program is running.
- Do not run the diagnostic program in a **windowing or multi-tasking environment**. The diagnostic program does not support these environments.
- Make sure there are no **terminate-stay-resident** (TSR) software programs loaded in your PS/2 before you run the diagnostic program.

The following sections describe how to start the diagnostic program from the:

- backup copy of the Options and Diagnostics diskette

OR

- hard disk

You are not required to start the diagnostic program from both the backup copy of the Options and Diagnostics diskette and the hard disk.

If you plan to start the diagnostic program from the hard disk, turn to the section “Starting Up from a Hard Disk” later in this document.

Starting Up from the Options and Diagnostics Diskette

Important: Before starting the diagnostic program from the backup copy of the Options and Diagnostics diskette, read the following:

- Do not remove the backup copy of the Options and Diagnostics diskette while the diagnostic program is running. The diagnostic program cannot write test results to the output file if the diskette is not in the floppy drive.
- Make sure the write protection switch on the Options and Diagnostics diskette is off when the diagnostic program is running. The diagnostic program cannot write test results to the output file if the write protection switch is on.
- Always exit the diagnostic program through the “exit” menu to avoid losing the output file.

To start the diagnostic program from the backup copy of the Options and Diagnostics diskette, follow the steps below:

1. Turn on your computer.
2. When the prompt appears, insert the backup copy of the Options and Diagnostics diskette.
3. Select the directory containing the diagnostic program by typing:

```
a: [ENTER]
```

When the prompt appears, type:

```
cd a:\ [ENTER]
```

Important: The diagnostic program adds new test results to results already existing in the output file. If you want to delete test results already existing in the output file, wait for the prompt to appear and type:

```
del kt2out.txt [ENTER]
```

Do this before you proceed to step 4.

4. When the prompt appears, type the following:

```
kt2diag [ENTER]
```

You see the following message:



WARNING: Serious damage will occur if 1784-KT2 is connected to a network. Press any key to acknowledge:

Make sure the 1784-KT2 is not connected to your network and press any key to continue.

5. Again you are asked if you want to continue. If you have followed the precautions to guard against network damage explained earlier in this section, type **y**. If you have not yet read this information, type **n** to exit the diagnostic program. You **must** read this information before going any further.
6. An Allen-Bradley copyright message appears on the screen. Press any key to continue.

The Allen-Bradley 1784-KT2 Diagnostic Program menu appears on your screen. You are now ready to run the diagnostic program as explained later in this document.

Starting Up from a Hard Disk

Important: We assume you have installed the diagnostic program onto the hard disk. If you have not done so, refer to the section earlier in this document.

In the following example, the hard disk is referred to as C:.

To start the diagnostic program from a hard disk, follow the steps below:

1. Turn on the computer.
2. Select the directory containing the diagnostic program by typing:

```
c: [ENTER]
```

When the prompt appears, type:

```
cd c:\kt2diag [ENTER]
```

Important: The diagnostic program adds new test results to results already existing in the output file. If you want to delete test results already existing in the output file, wait for the prompt to appear and type:

```
del kt2out.txt [ENTER]
```

Do this before you proceed to step 3.

3. When the prompt appears, type:

```
kt2diag [ENTER]
```

You see the following message:



WARNING: Serious damage will occur if 1784-KT2 is connected to a network. Press any key to acknowledge:

Make sure your 1784-KT2 is not connected to your network and press any key to continue.

4. Again you are asked if you want to continue. If you have followed the precautions to guard against network damage explained earlier in this section, type **y**. If you have not yet read this information, type **n** to exit the diagnostic program. You **must** read this information before going any further.
5. An Allen-Bradley copyright message appears on your screen. Press any key to continue.

The Allen-Bradley 1784-KT2 Diagnostic Program menu appears on your screen. You are now ready to run the diagnostic program.

Running the Diagnostic Program

When you have completed the start-up procedures, the following screen appears:

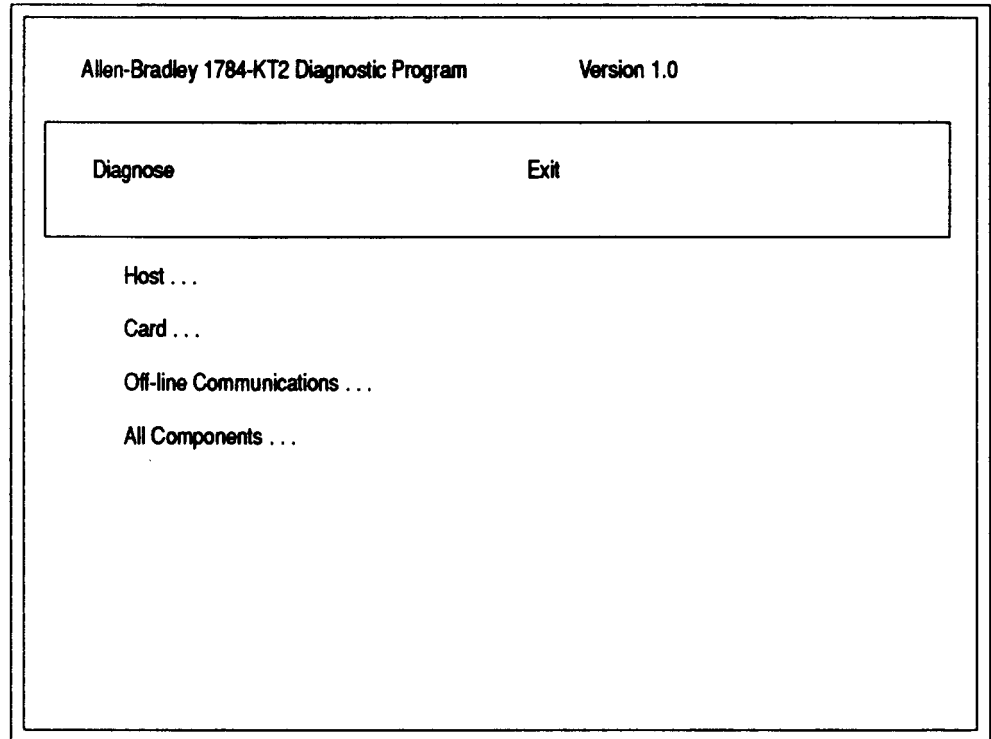

F3 - Select Module

You must now specify which 1784-KT2 module you want to test. To do this, follow the steps below:

1. Press [F3]. The number of each slot containing a 1784-KT2 is displayed.
2. Specify the slot number of the 1784-KT2 you want to test by moving the cursor to the desired slot number and pressing [ENTER]. You can press [F3] to select a new module whenever [F3] appears on the screen.

The following sections describe each of the above diagnostic options.

The Host Diagnostics Test

The Host Diagnostics option allows you to test for proper communication between the PS/2 computer and the 1784-KT2. To perform this test, follow the steps below:

1. Place your cursor on the Host option and press [ENTER].
2. You are asked if you want to run a single test (Single Pass) or a specified number of tests (Repeat). Place your cursor on Single Pass or on Repeat and press [ENTER].

If you choose Repeat, you are asked how many passes you want to make. Specify this number and press [ENTER].

After you make your selection, the following screen appears:

Allen-Bradley 1784-KT2 Diagnostic Program		Version 1.0	
Diagnose		Exit	
HOST DIAGNOSTICS	Status:	Pass:	Of:
DIAGNOSTIC		FAILURES	RESULT
Configuration			
Memory Address	_____		
Interrupt Level	_____		
Mode Selection	_____		
Adapter Id	_____		
Dual Port (PS2 side)	_____		
Power On/Reset	_____		
Interrupts (KT2 to PS2)	_____		

Press any key to return to Main Menu

Table 2 describes each of the above terms.

Table 2
Host Diagnostics Screen Definitions

This term:	Indicates:
Configuration	the 1784-KT2's configuration parameters.
Memory Address	the 1784-KT2's configured memory address.
Interrupt Level	the 1784-KT2's configured interrupt level.
Mode Selection	the 1784-KT2's configured auxiliary communication port.
Adapter ID	the 1784-KT2's adapter identification number (60C6).
Dual Port (PS2 side)	test results of the PS/2's ability to read/write to and from the dual port memory. If any errors occur, the failure counter increments and continues with the next text.
Power On/Reset	test results of the PS/2's ability to reset the 1784-KT2. After reset, the 1784-KT2's status and execution capabilities are verified. If any errors occur, the failure counter increments and continues with the next test.
Interrupts (KT2 to PS2)	test results of the interrupt capabilities from the 1784-KT2 to the PS/2. If the PS/2 cannot receive an interrupt from the 1784-KT2, the failure counter increments and continues with the next test.

The Host Diagnostics test runs according to the number of times specified in step two. Your screen shows you when the tests are complete (Status column), how many errors were discovered (Failures column), and final test results (Result column).

3. When you are finished, press any key to return to the main menu.

The Card Diagnostics Test

The Card Diagnostics option allows you to test the 1784-KT2's various components and operations. To perform this test, follow these steps:

1. Place your cursor on the Card option and press [ENTER].
2. You are asked if you want to run a single test (Single Pass) or a specified number of tests (Repeat). Place your cursor on Single Pass or on Repeat and press [ENTER].

If you choose Repeat, you are asked how many passes you want to make. Specify this number and press [ENTER].

After you make your selection, the following screen appears:

Allen-Bradley 1784-KT2 Diagnostic Program		Version 1.0	
Diagnose		Exit	
CARD DIAGNOSTICS	Status:	Pass:	Of:
DIAGNOSTIC		FAILURES	RESULT
Start/Stop 1784-KT2 Processor (Z80 CPU)	-----		
Dual Port (KT2 side)	-----		
Interrupts (PS2 to KT2)	-----		
Memory	-----		
Timer Operation	-----		
Serial Port Operation	-----		

Press any key to return to Main Menu

Table 3 describes each of the above terms.

Table 3
Card Diagnostics Screen Definitions

This term:	Indicates:
Start/Stop 1784-KT2 Processor (Z80 CPU)	tests results of the PS/2's ability to perform a software reset of the 1784-KT2. After the reset, the 1784-KT2's status and execution capabilities are verified. If any errors occur, the failure counter increments and continues with the next test.
Dual Port (KT2 side)	tests results of the 1784-KT2's ability to read from and write to the dual port memory. If any errors occur, the failure counter increments and continues with the next test.
Interrupts (PS2 to KT2)	test results of the interrupt capabilities from the PS/2 to the 1784-KT2. If the 1784-KT2 cannot receive an interrupt from the PS/2, the failure counter increments and continues with the next test.
Memory	test results of the 1784-KT2's ability to read from and write to the 1784-KT2's internal memory chips. If any errors occur, the failure counter increments and continues with the next test.
Timer Operation	test results of the accuracy and capabilities of the 1784-KT2's counter-timer chips. If any errors occur, the failure counter increments and continues with the next test.
Serial Port Operation	test results of the interrupts and loopback capabilities of the 1784-KT2's Serial I/O chip. If any errors occur, the failure counter increments and continues with the next test.

The Card Diagnostics test runs according to the number of times specified in step two. Your screen shows you when the tests are complete (Status column), how many errors were discovered (Failures column), and final test results (Results column).

3. When you are finished, press any key to return to the main menu.

The Off-Line Communications Diagnostics Test

The Off-Line Communications option allows you to test the communication capabilities of the 1784-KT2.

Important: To perform the Off-Line Communications diagnostics, you must build a loopback connector. Refer to the section, “Building Loopback Connectors” later in this document for more information.

The Off-Line Communications test performs two loopback tests. These tests are performed across:

- the auxiliary (PLC-2 or PLC-3) port. This loopback test checks the pins used to directly connect the 1784-KT2 to either a PLC-2 or PLC-3. You specify which PLC function you want to test and attach the corresponding loopback connector to the 1784-KT2.
- the main (Data Highway Plus) port. This loopback test checks the pins used to connect the 1784-KT2 to the Data Highway Plus network. This port accepts either loopback connector (you must choose one).

To perform an Off-Line Communications test, follow these steps:

1. Depending on which set of auxiliary port pins you want to test, install either the PLC-2 or PLC-3 loopback connector.
2. Place your cursor on the Off-Line Communications option and press [F4].
3. You are asked to select a direct connect function of the auxiliary port, Press [F2].
4. The PLC-2 and PLC-3 direct connect functions are displayed. If you want to test the pins used to connect the 1784-KT2 to a PLC-2, place your cursor on the PLC-2 function and press [ENTER]. If you want to test the pins used to connect the 1784-KT2 to a PLC-3, place your cursor on the PLC-3 function and press [ENTER].
5. Press [ESC] to return to the main menu. You can press [F4] to select anew direct connect function whenever [F4] appears on your screen.
6. Press [ENTER]. You are asked if you want to run a single test (Single Pass) or a specified number of tests (Repeat). Place your cursor on Single Pass or on Repeat and press [ENTER].

If you choose Repeat, you are asked how many passes you want to make. Specify this number and press [ENTER].

After you make your selection, the following screen appears (in this example, the PLC-2 function is displayed):

```

Allen-Bradley 1784-KT2 Diagnostic Program          Version 1.0
-----
Diagnose                                     Exit
-----
OFF-LINE COMMUNICATION DIAGNOSTICS  Status: RUNNING  Pass:      Of: 1
-----
DIAGNOSTIC                               FAILURES  RESULT
-----
DH+
PLC-2
-----

Install loopback cable with PLC2 compatibility. Are you ready to begin?
Press "Y" for yes and any other key for no:
  
```

Press any key to return to Main Menu

Table 4 describes each of the above terms.

Table 4
Off-line Communications Diagnostics Screen Definitions

This term:	Indicates:
DH+	test results of the loopback test. This loopback test checks the capability of the Data Highway Plus (DH+) channel on the SIO (main port) chip. If any errors occur, the failure counter increments and continues with the next test.
PLC-2 (or PLC-3)	test results of the loopback test. This loopback test checks the capability of the PLC-2 (or PLC-3) channel on the SIO (auxiliary port) chip. If any errors occur, the failure counter increments and continues with the next test.

- You are asked to install your loopback connector with PLC-2 or PLC-3 capability. Make sure your loopback connector is installed and press [Y].

The Off-Line Communications test runs according to the number of times specified in step six. Your screen shows you when the tests are complete (Status column), how many errors were discovered (Failures column), and final test results (Results column).

- When you are finished, press any key to return to the main menu.

The All Components Diagnostic Test

The All Components option allows you to run the Host, Card, and Off-line Communications tests discussed in the previous sections. To perform an All Components test, follow these steps:

1. Install your PLC-2 or PLC-3 loopback connector.
2. Place your cursor on the All Components option and press [F4].
3. Follow steps 3 through 8 of the Off-line Communications test.

Error Messages

Table 5 lists possible error messages you may receive when running the diagnostic program.

Table 5
Diagnostics Program Error Messages

This error message:	Indicates:
2 Ram0 Failure	the 1784-KT2 cannot read or write to the RAM0 chip, or the 1784-KT2 is configured at an address already in use.
4 KT2 Dual Port Failure	the 1784-KT2 cannot read or write to the dual port, or the 1784-KT2 is configured at an address already in use.
8 CTC Timer Mode Failure	the timer on the counter-timer chip (CTC) is functioning improperly.
9-19 Diagnostic File KT2STXXX.BIN Open or Missing	the KT2STXXX.BIN file is not in the KT directory. Make sure all delivered files with the extension BIN are in the A:\KT or C:\KT directory.
16 CTC Counter Mode Failure	the counter on the CTC chip is functioning improperly.
24 CTC Timer/Counter Mode Failure	the CTC chip's timer, counter, or both are functioning improperly.
32 SIO Channel A Failure- No Interrupts	interrupts to the Serial Input/Output (SIO) channel A are functioning improperly.
64 SIO Channel A Failure- No Loopback	data communications to and from the SIO channel A have failed.
15 Host Dual Port Failure	the diagnostic program cannot read or write to the dual port, or the 1784-KT2 is configured at an address already in use.
17 Board Held at Reset	the 1784-KT2 will not start, or the 1784-KT2 is configured at an address already in use.
128 RAM 1 Failure	the 1784-KT2 cannot read or write to the RAM1 chip, or the 1784-KT2 is configured at an address already in use.
130 RAM0, RAM1 Failure	the 1784-KT2 cannot read or write to both the RAM0 and RAM1 chips, or the 1784-KT2 is configured at an address already in use.
132 RAM1, Dual Port Failure	the 1784-KT2 cannot read or write to the RAM1 or dual port chip, or the 1784-KT2 is configured at an address already in use.

This error message:	Indicates:
48-56 Diagnostic Time-outs	the 1784-KT2 cannot be started or stopped, or the 1784-KT2 is configured at an address already in use, or a dual port memory error has occurred, either on the 1784-KT2 side or the PS/2 side, preventing download or execution of the test.
52 Card Interrupt Time-out	possibly any of the same problems listed for the Diagnostic Time-out error message, or the interrupts from the PS/2 to the 1784-KT2 are not working.
62 KT2 to PS/2 Interrupt Failure	interrupts from the 1784-KT2 to the PS/2 are not functioning properly.
66 Status Register Indicates 1784-KT2 Start Failure	the 1784-KT2 started, but the status register does not indicate this.
68 Status Register Indicates 1784-KT2 Stop Failure	the status register does not indicate that the 1784-KT2 stopped, or the 1784-KT2 did not stop when commanded to.
70 Interrupt Successful but Status Register is Inaccurate	the status register does not indicate a successful interrupt.
85 Off-line RTS CTS error	data control communication to and from the SIO channel B (PLC-2 function) has failed.
86 Off-line Data Error	data communication to and from the SIO channel B (PLC-2 or PLC-3 function) has failed.

Output File

The output file (KT2OUT.TXT) provides detailed error message information gathered from the diagnostic program. The output file displays each test that was run, as well as final test results. Each time the diagnostic program runs, it adds the test results to the output file.

The output file has a maximum file size of 250K. If you reach this limit, a message will appear under the title bar on your screen and in your output file. The diagnostic program will continue to run tests if this maximum file size is reached, but it will not record the test results in the output file. If you want to record test results in the output file but have reached the 250K limit, you must delete the file (see the section entitled “Starting-Up the Diagnostic Program” for information on how to delete the output file).

If an error occurs during a test, the final results section will show you which diagnostic failed and the amount of times it failed.

Figure 4 shows an example of a Card Diagnostics test.

Figure 4
The Output File For a Card Diagnostics Test

```

CARD DIAGNOSTICS           PASS: 1   OF 2   Wed Aug 22 11:48:13 1990
Start/Stop 1784-KT2 Proce . . . NUM FAILS: 0   PASS/FAIL: PASS
Error: No error found.

Dual Port (KT2 side) . . . . . NUM FAILS: 0   PASS/FAIL: PASS
Error: No error found.

Interrupts (PS2 to KT2) . . . . . NUM FAILS: 0   PASS/FAIL: PASS
Error: No error found.

Memory . . . . . NUM FAILS: 1   PASS/FAIL: FAIL
Error Code: 128 RAM1 Failure.

Timer Operation . . . . . NUM FAILS: 1   PASS/FAIL: FAIL
Error Code: 16 CTC Counter
Mode Failure.

Serial Port Operation . . . . . NUM FAILS: 0   PASS/FAIL: PASS
Error: No error found.

CARD DIAGNOSTICS           PASS: 2   OF 2   Wed Aug 22 11:48:16 1990
Start/Stop 1784-KT2 Proce . . . NUM FAILS: 0   PASS/FAIL: PASS
Error: No error found.

Dual Port (KT2 side) . . . . . NUM FAILS: 0   PASS/FAIL: PASS
Error: No error found.

Interrupts (PS2 to KT2) . . . . . NUM FAILS: 0   PASS/FAIL: PASS
Error: No error found.

Memory . . . . . NUM FAILS: 0   PASS/FAIL: PASS
Error: No error found.

Timer Operation . . . . . NUM FAILS: 0   PASS/FAIL: PASS
Error: No error found.

Serial Port Operation . . . . . NUM FAILS: 0   PASS/FAIL: PASS
Error: No error found.

CARD DIAGNOSTICS           FINAL RESULTS   Wed Aug 22 11:48:17 1990
Start/Stop 1784-KT2 Proce. . . . NUM FAILS: 0   PASS/FAIL: PASS

Dual Port (KT2 side) . . . . . NUM FAILS: 0   PASS/FAIL: PASS

Interrupts (PS2 to KT2) . . . . . NUM FAILS: 0   PASS/FAIL: PASS

Memory . . . . . NUM FAILS: 1   PASS/FAIL: FAIL

Timer Operation . . . . . NUM FAILS: 1   PASS/FAIL: FAIL

Serial Port Operation . . . . . NUM FAILS: 0   PASS/FAIL: PASS
  
```

In the above example, the Card Diagnostics test was run twice. The timer operation and the memory diagnostics show errors in the first pass of tests and none in the second pass. The final results section indicates the failure of both diagnostics from the first run of tests.

Building Loopback Connectors

This section shows you how to build the PLC-2 and PLC-3 loopback connectors required for Off-Line Communications Diagnostics tests. Two loopback tests are performed during an Off-Line Communications test. In a loopback test, you download a program to the 1784-KT2 which:

- transmits a packet of data
- receives the same packet of data
- verifies that the transmitted and received packets are identical

For more information on loopback tests, see the section entitled “The Off-Line Communications Diagnostics Test.”

To build the PLC-2 and PLC-3 loopback connectors, you will need the following items:

Table 6
Required Items for Building a Loopback Connector

Item:	Quantity:	AMP Part No.:
Connector housing	2	748367-1
Contact pins	16	748333-4
Hand-crimp tool	1	90430-1
22-28 AWG wire	2 ft	(none)

Important: To ensure correct and reliable assembly, use the hand-crimp tool with the AMP part number listed above.

Also, the maximum insulation diameter for each wire is 0.04”.

To build the PLC-2 and PLC-3 loopback connectors, follow the steps below:

1. Cut eight 3-inch sections of wire.
2. Strip 0.2” of insulation off each end of wire.
3. Using the crimp tool, crimp the contact pins onto each end of wire.

4. Insert 5 of the wires into the back of a connector housing according to the following PLC-2 wire-assembly diagram. Label this connector PLC-2.

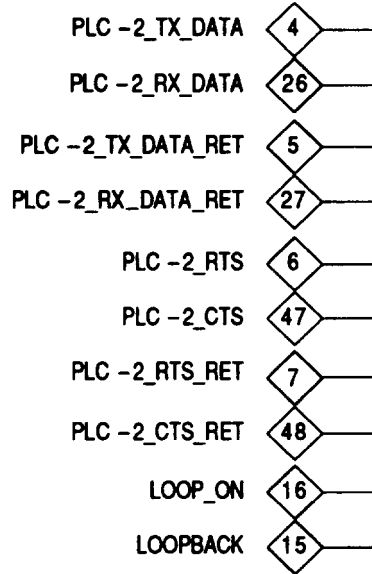

18342

5. Insert 3 of the wires into the back of the remaining connector housing according to the PLC-3 wire-assembly diagram shown below. Label this connector PLC-3.

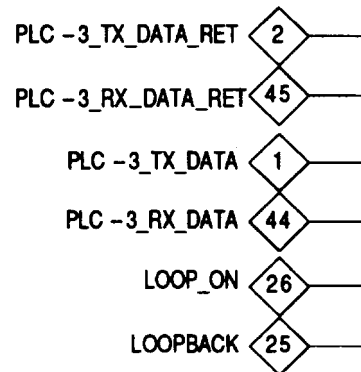

18343

Specifications

Specifications for the 1784-KT2 are listed below.

Module Location	IBM PS/2 computer, 8/16-bit MicroChannel slot
Module Output Connector	62-pin D-shell
Outputs	PLC-2 serial interface PLC-3 serial interface Data Highway Plus
Module Compatibility	Allen-Bradley 6123 Allen-Bradley 6124 IBM PS/2
Hardware Interrupt	IRQ9 IRQ10 IRQ11 IRQ12
Baud Rate	Asynchronous (PLC-2, PLC-3): 9600; 19.2K Synchronous (Data Highway Plus): 57.6K
Maximum Line Length	PLC-2: 10ft (3m) PLC-3: 10ft (3m) Data Highway Plus, PLC-3 and PLC-5: 10,000ft (3050m) @ 57.6Kbaud
Power Requirements	+ 5V dc @ 0.25A (1W) ± 12V dc @ 0.04A (0.48W)
Operating Temperature	32 to 113°F (0 to 45°C)
Humidity	5 to 95% noncondensing
Regulatory Compliance	FCC Class A

IBM PS/2 is a registered trademark of International Business Machines Corporation.



ALLEN-BRADLEY
A ROCKWELL INTERNATIONAL COMPANY

As a subsidiary of Rockwell International, one of the world's largest technology companies — Allen-Bradley meets today's challenges of industrial automation with over 85 years of practical plant-floor experience. More than 11,000 employees throughout the world design, manufacture and apply a wide range of control and automation products and supporting services to help our customers continuously improve quality, productivity and time to market. These products and services not only control individual machines but integrate the manufacturing process, while providing access to vital plant floor data that can be used to support decision-making throughout the enterprise.

With offices in major cities worldwide

**WORLD
HEADQUARTERS**
Allen-Bradley
1201 South Second Street
Milwaukee, WI 53204 USA
Tel: (1) 414 382-2000
Telex: 43 11 016
FAX: (1) 414 382-4444

**EUROPE/MIDDLE
EAST/AFRICA
HEADQUARTERS**
Allen-Bradley Europe B.V.
Amsterdamseweg 15
1422 AC Uithoorn
The Netherlands
Tel: (31) 2975/43500
Telex: (844) 18042
FAX: (31) 2975/60222

**ASIA/PACIFIC
HEADQUARTERS**
Allen-Bradley (Hong Kong)
Limited
Room 1006, Block B, Sea
View Estate
28 Watson Road
Hong Kong
Tel: (852) 887-4788
Telex: (780) 64347
FAX: (852) 510-9436

**CANADA
HEADQUARTERS**
Allen-Bradley Canada
Limited
135 Dundas Street
Cambridge, Ontario N1R
5X1
Canada
Tel: (1) 519 623-1810
FAX: (1) 519 623-8930

**LATIN AMERICA
HEADQUARTERS**
Allen-Bradley
1201 South Second Street
Milwaukee, WI 53204 USA
Tel: (1) 414 382-2000
Telex: 43 11 016
FAX: (1) 414 382-2400